



A Cross-Domain Systematic Mapping Study on Software Engineering for Digital Twins

Manuela Dalibor^{1,*}, Nico Jansen¹, Bernhard Rumpe¹, David Schmalzing¹, Louis Wachtmeister¹, Manuel Wimmer²,
Andreas Wortmann³

Abstract

Digital Twins are currently investigated as the technological backbone for providing an enhanced understanding and management of existing systems as well as for designing new systems in various domains, e.g., ranging from single manufacturing components such as sensors to large-scale systems such as smart cities. Given the diverse application domains of Digital Twins, it is not surprising that the characterization of the term Digital Twin, as well as the needs for developing and operating Digital Twins are multi-faceted. Providing a better understanding what the commonalities and differences of Digital Twins in different contexts are, may allow to build reusable support for developing, running, and managing Digital Twins by providing dedicated concepts, techniques, and tool support. In this paper, we aim to uncover the nature of Digital Twins based on a systematic mapping study which is not limited to a particular application domain or technological space. We systematically retrieved a set of 1471 unique publications of which 356 were selected for further investigation. In particular, we analyzed the types of research and contributions made for Digital Twins, the expected properties Digital Twins have to fulfill, how Digital Twins are realized and operated, as well as how Digital Twins are finally evaluated. Based on this analysis, we also contribute a novel feature model for Digital Twins from a software engineering perspective as well as several observations to further guide future software engineering research in this area.

© 2011 Published by Elsevier Ltd.

Keywords: Software Engineering, Digital Twins, Manufacturing, Industry 4.0

1. Introduction

Research and industry leverage Digital Twins to monitor and control (cyber-physical) systems in various domains, including autonomous driving [104], biology [266], medicine [26], smart manufacturing [256], and many more. They promise tremendous potential to reduce cost and time and improve our understanding of the represented systems. The various Digital Twins serve different purposes, including analysis [214], control [292], and behavior prediction [66], and they are used at different times relative to the represented system, e.g., before it exists to explore its design space [274] or during its runtime to optimize its behavior [1]. Despite plethora of definitions [70, 115, 166, 179, 253] there is little consensus about what a Digital Twin actually is. This also is reflected in many of the available definitions

*All authors contributed equally to this research.

Email addresses: dalibor@se-rwth.de (Manuela Dalibor), jansen@se-rwth.de (Nico Jansen), rumpe@se-rwth.de (Bernhard Rumpe), schmalzing@se-rwth.de (David Schmalzing), wachtmeister@se-rwth.de (Louis Wachtmeister), manuel.wimmer@jku.at (Manuel Wimmer), andreas.wortmann@isw.uni-stuttgart.de (Andreas Wortmann)

¹Software Engineering, RWTH Aachen University, Germany

²Department of Business Informatics – Software Engineering, Johannes Kepler University Linz, Austria

³Institute for Control Engineering of Machine Tools and Manufacturing Unit (ISW), University of Stuttgart, Germany

being (1) ambiguous, by deferring to another undefined term, such as a “virtual representation” [311], a “computable virtual abstraction” [251], or a “a virtual projection of the industrial facility into the cloud” [53]; (2) narrow, by focusing on specific use cases, domains, or technologies, such as a “digital model of the real network environment” [88] or a “virtual representation based on AR-technology” [214]; or (3) utopian, due to all-encompassing aspirations, such as an “integrated virtual model of a real-world system containing all of its physical information” [92], a “complete digital representation” [65]. Instead of producing more of such definitions, we aim to uncover the nature of Digital Twins as documented in literature bottom-up. To this end, we conducted a systematic mapping study [385, 386, 387] on Digital Twins to investigate the following research questions (RQs):

- Who uses Digital Twins for which purposes (**RQ-1**)?
- What are the conceptual properties of Digital Twins (**RQ-2**)?
- How are Digital Twins engineered (**RQ-3**), deployed (**RQ-4**), and operated (**RQ-5**)?
- To which extent are Digital Twins evaluated (**RQ-6**)?

Following a detailed search strategy involving five digital libraries, we initially found 1472 unique publications. Out of these, 624 publications were identified as potentially relevant of which 356 publications were finally selected and categorized using a comprehensive classification scheme focusing on the contribution types, research types, properties, implementation methods, deployment details, operation decisions, and evaluation means of Digital Twins. The resulting research landscape developed by this study can help to understand, guide, and compare future research in this field across different domains. In particular, this paper identifies common and varying Digital Twin features and identifies challenges that seem to be less investigated. The contributions of this paper, hence, are

1. A first systematic and comprehensive study on Digital Twins across different domains, applied implementation technologies, and purposes.
2. A novel feature model of common Digital Twin features to guide researchers and practitioners in making decisions about the design, development, deployment, and operation of Digital Twins.
3. A synthesis of observations on the landscape of Digital Twin research that may guide further research.

In the following, Section 2 presents related studies and discusses how our survey differs in width, depth, and research method. Afterward, Section 3 details our research method, questions, queries, and data collection. Then, Section 4 answers these research questions individually and Section 5 investigates correlations between the answers to these questions. Based on our findings, Section 6 presents a novel model of common Digital Twin features. Section 7 discusses threats to the validity of our survey, and finally, Section 8 concludes the paper with an outlook on future work.

2. Related Studies

Research has produced a variety of studies on Digital Twins, their features, and their application. This section relates these studies to our investigation.

Studies on Features and Characteristics of Digital Twins

The survey presented in [376] reduces an initial corpus of 579 publications to 233 included publications to identify a Digital Twin classification schema of eight features. The systematic survey on themes in Digital Twin research presented in [398] investigates a corpus of 92 publications obtained by using Google Scholar as data source solely and the artificial cut-off criterion to consider the first 500 search results only. In this study, the authors identify 19 themes of Digital Twin research, such as managing a physical entity, fidelity of the Digital Twin, and the twinning process itself. Ultimately, the authors suggest a more detailed comparison of Digital Twins and publications from related fields. Through the study, the authors identify 13 key characteristics of Digital Twins, including the nature of the twinned system and its environment (both of which can be physical or virtual) and how its connections are realized (physical-to-virtual and vice versa), and similar. Hence, the study predisposes interesting assumptions about Digital Twins,

such as that there is a connection between the twinned system and the Digital Twin. Another systematic literature study considers 82 publications out of an initial corpus of 1300 publications to identify features and characteristics of Digital Twins in the oil & gas industry [401]. For the oil & gas industry, the authors of [401] identify asset performance management, asset risks, and support for virtual training to navigate and operate assets as the most important drivers for Digital Twin research. These priorities reflect the complex and often remote nature of assets in the oil & gas industry, and we expect these not to apply to general Digital Twin research in the same order. Moreover, that survey identifies challenges to Digital Twin engineering and identify the lack of scope and focus, the lack of standardization, and security issues as most important in their domain.

In the context of Industry 4.0, various studies touch on the topic of Digital Twins. For instance, a strategic roadmap towards Industry 4.0 [365] identifies Digital Twins as the goal of the smart manufacturing strategy for the transition to Industry 4.0. Here, Digital Twins are considered as a vision combining data analytics provided by intelligent enterprise resource planning (ERP) systems and data collected from the manufacturing machines. Achieving this vision is left as subject for future work.

Studies on Engineering Digital Twins

Various studies address the question of how Digital Twins are engineered by investigating the requirements [366], architectures [374, 364], and the technologies [377] used with Digital Twins. Some of these focus on a specific domain, such as the study of 43 publications on engineering Digital Twins in manufacturing presented in [374]. In contrast, others have a wider scope, such as the survey of over 137 publications reported in [377] or the study of 52 publications on requirements for Digital Twins [366]. In [374], the authors categorize a corpus of 43 publications on Digital Twins according to the type of contribution (case study, concept, definition, review), level of integration (which describes the nature of the contribution as being a Digital Twin, a Digital Shadow, or a model), application domain, and employed technologies (including AutomationML, simulation, SAP, RFID, etc.). Based on their data, the authors conclude that research on the Digital Twin is still “in its infancy”. Our study presented in this paper may allow to confirm or reject whether this still is the case.

In [377], the authors investigate many interesting research questions from the nature of Digital Twins to their essential features to potentials for the evolution of the Digital Twin idea. Their process for selecting the included 137 publications is not further discussed. In another survey on requirements for Digital Twins in the context of Industry 4.0 [366], the authors analyze 52 publications obtained via Web of Science and combine the insights from their corpus with interviews of six industry representatives. Overall, they identify real-time data handling, integration, and fidelity as the main requirements for Digital Twins in their context.

Similar studies focus on particular aspects of Digital Twin engineering, such as the relation of Digital Twins to product lifecycle management systems [367], the synchronization of Digital Twins with their counterparts [372], or architectures for installed base management systems [364]. The authors of [367] investigate an initial corpus of 256 publications and reduce it to include 123 publications ultimately. Analyzing the resulting corpus, the authors conclude that, among communication, representation, and computation, microservices are a quintessential technical basis for Digital Twins. Moreover, they find that Digital Twins are primarily used in manufacturing and that Digital Twins contribute not only to asset control but also to strategic business aspects. The survey on the synchronization of Digital Twins with their counterparts [372], identifies granularity of the synchronization, the management of real-time and historical data, proper data distribution, and operability with production resources as the main synchronization challenges for employing Digital Twins. The authors of [364] categorize 18 selected publications on installed base management systems architecture for manufacturing and investigate which aspects (such as communication, data quality, security, or Digital Twin) these address. They find that only three architectures for installed base management systems provide capabilities to serve as Digital Twins and suggest future work in this direction.

Another study investigates technologies and tools for Digital Twins [399]. The authors identify Digital Twins as 5-tuples consisting of physical entities, virtual models, data, services, and connections. Based on this assumption, the authors discuss how the different parts of Digital Twins relate, which tasks the different parts of Digital Twins have and which kinds of tools, such as “tools for data storage”, “tools for behavior modeling”, etc., are necessary to realize Digital Twins. The study lists specific instances to guide practitioners in selecting suitable tools for engineering Digital Twins for these categories. In another study of 26 publications on Digital Twins and Digital Shadows [397], the authors investigate the areas that Digital Twins are applied to and which kinds of paradigms are employed to

achieve this [379]. According to this study, manufacturing is the most prominent domain for Digital Twins, whereas Industry 4.0, artificial intelligence, and simulation are the most important paradigms.

A review on sustainable, intelligent manufacturing with Digital Twins discusses which equipment, systems, and services are required to achieve this vision [368]. The paper presents a framework of sustainable intelligent manufacturing through Digital Twins featuring from a very abstract vantage point, which suggests that, among others, artificial intelligence, 5G, the Internet of Things, are part of this vision. However, the review does not suggest processes, methods, or tools for engineering or operating Digital Twins.

Studies on the Application of Digital Twins

Other studies investigate the application of Digital Twins. Some of these also are focused on specific domains, such as the study of 13 publications applying Digital Twins in construction [375], the survey of 26 publications on the use of Digital Twins in manufacturing [369], or the survey about 23 publications on Digital Twins in smart, interconnected factories [370]. In the latter, the authors identify a “Digital Twin lifecycle” being one of the key enablers for smart manufacturing networks. Some studies with narrow focus include larger corpora, such as the survey about 110 publications on Digital Twins in smart manufacturing [371]. Some of these studies are less narrow, such as the investigation of 50 studies on Digital Twins in multiple industrial domains [373]. The latter’s findings are that (asset) prognostics and health management is the most popular application area for industrial Digital Twins, that modeling is essential for engineering Digital Twins, and that main challenges in Digital Twin application is bridging the gap between cyber parts and physical parts. The survey presented in [378] investigates how Digital Twin implementations could be evaluated and presents a grading schema for Digital Twins based on an initial corpus of 16 publications.

Studies on Literature about Digital Twins

Moreover, a few meta-studies investigate, for instance, how Digital Twins are described in the literature [380], what the most frequently used terms for describing Digital Twin challenges in high-value manufacturing are [363], or which definitions are used to describe Digital Twins [400]. For instance, in [363], the authors identify the 75 most often used terms to describe Digital Twins (the top 3 being “system”, “data”, and “physical”) and analyze which topics these belong to. Based on that analysis, the authors produce 11 clusters of Digital Twin topics (including engineering, standards, scalability, cost & time, cyber-physical system (CPS), data, user interaction, and more) and summarize the challenges in high-value manufacturing relating to these clusters. The study presented Digital Twins [400], does not consider terminology used to describe Digital Twins but considers explicit definitions only. Based on an ad-hoc literature analysis, the authors collected 19 definitions and identify eight Digital Twin dimensions, including “connectivity mode”, “CPS intelligence”, “simulation capabilities”, and “human interaction”.

Synopsis

Most of the mentioned related studies have a particular scope and depth as well as a certain level of systematic rigor. Hence, they only address a subset of the research questions investigated within this study, consider smaller corpora, or cannot be fully reproduced with the information presented in the corresponding publications. For the latter, there is often a lack of information about the selected data sources, search query, and inclusion/exclusion criteria. Thus, a larger and detailed study on Digital Twin concerns across different domains in a fully reproducible manner is still missing, especially when it comes to the software engineering of Digital Twins.

3. Research Method

A systematic mapping study identifies publications within a research field and classifies these according to pre-defined, structured criteria [386]. Thus, it provides an overview of the topics and contribution types for a research domain to analyze the current status, challenges, and general progress. We have based our study on generally approved guidelines [386, 392] and practices of other mapping studies [361, 393, 394, 395]. To conduct this study, we have used the following five-step process (based on [386]): (1) Definition of the research questions, (2) Search for primary publications, (3) Identification of inclusion and exclusion criteria and filtering of primary sources based on these, (4) Classification of primary studies by keywording, and (5) Extraction and aggregation of data.

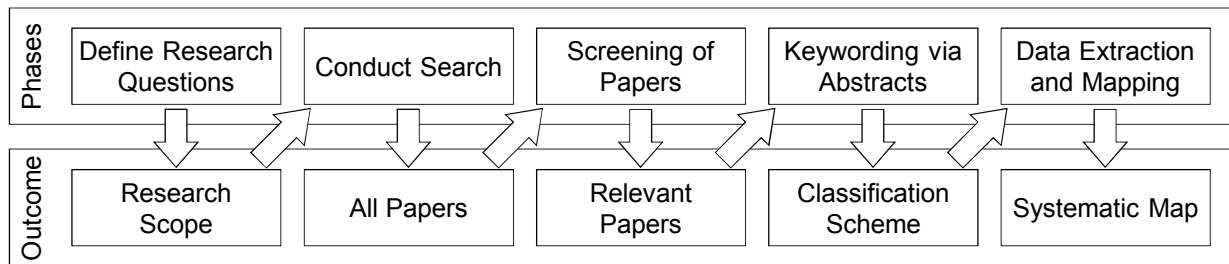

Figure 1: Phases and outcomes of a systematic mapping study [386]

Figure 1 visualizes this process with its phases and their outcomes. In the first phase, the scope of the mapping study is defined. This includes the research questions as well as the overall topics of the publications to be considered. In the second phase, we collected the corpus of potentially relevant publications for our study. Afterward, in the third phase, we analyzed the corpus according to defined criteria and reduced it to conduct our study only on thematically relevant contributions. Based on abstract and keywords, we then derived an initial classification scheme (cf. Phase 4). Finally, the relevant publications were examined (based on full reads) and classified in Phase 5, mapping the identified classes to the number of findings and findings cross-related as well as mapped to software engineering phases to provide answers to the research questions described in the following.

3.1. Research Questions

We aim to identify publications on Digital Twins to investigate how they are defined, how they are engineered and used, and to document the current state-of-the-art. Furthermore, we analyze the different goals that application domains pursue with Digital Twins concerning their real-world counterparts and overall lifetime. This general research interest results in the following research questions. However, not every paper is expected to provide an answer to every question. Therefore, some information on certain facets may not be available (N/A).

1. Who uses Digital Twins for which purposes?

These questions aim to identify which application domains research in Digital Twins targets and which concerns and challenges the publications on Digital Twins address.

RQ-1.1 *Which domains employ Digital Twins?* With this question we aim to understand where Digital Twins are meant to be employed. This might shed light onto domains that are either particularly interested in Digital Twins or particularly suited for their application.

RQ-1.2 *What is the purpose of these Digital Twins?* Digital Twins might be investigated for a variety of reasons. This question aims to identify these.

2. What are the conceptual properties of Digital Twins?

A central focus of our study lies on investigating the conceptual properties of Digital Twins and their fundamental concepts. We explore, which properties and parts are associated with the twin and determine the subjects that can be twinned. Moreover, we identify whether a Digital Twin is unique to its counterpart and how these entities communicate. The questions concerning this topic are:

RQ-2.1 *What is the real-world counterpart (i.e., the observed entity)?* This question aims to understand what is represented by Digital Twins.

RQ-2.2 *How are multiple Digital Twins of the same observed entity supported?* Research contributes different perspectives on supporting multiple Digital Twins for (aspects) of the same system. We aim to identify how the different perspectives are supported.

RQ-2.3 *When is the Digital Twin used in the lifecycle of the observed entity?* Digital Twins can be used before the twinned system exists, during its deployment, for its operations, or even after. We aim to find out how the different lifecycle phases are supported by Digital Twins.

RQ-2.4 *What stage of the observed entities lifecycle use does it represent?* Orthogonal to **RQ-2.3**, Digital Twins can represent different lifecycle stages of the twinned system, e.g., during system runtime a Digital Twin of the system as-designed might be employed as no other, more up-to-date twin, is available.

RQ-2.5 *How does the Digital Twin interact with its real-world counterpart?* Some schools of Digital Twin thought propose that a software system can be a Digital Twin only if there is a direct interaction from it to the twinned system. With this question, we aim to find out whether this is a common perspective.

RQ-2.6 *What (if anything) does the Digital Twin optimize?* A Digital Twin might optimize the behavior of the twinned system, itself, or nothing at all, e.g., if it is only monitoring the twinned system. We aim to find out which optimizations are supported by Digital Twins.

RQ-2.7 *What does a Digital Twin consist of?* There is a scientific debate whether a Digital Twin *is* a model, a software system, or whether it even includes physical parts (such as hardware for augmented reality). With this question, we aim to find out what are common parts of Digital Twins.

RQ-2.8 *Are Digital Twins decomposable?* (De)composition is a quintessential software engineering for supporting reuse. We aim to find out whether research on Digital Twins supports it as well.

3. How are Digital Twins engineered?

These questions aim to identify the means to construct Digital Twins. To this end, it explores how the different parts and properties are realized for implementing these twins. We focus on technical details such as concrete realization, communication, or associations with product lifecycle management. Furthermore, we investigate different tools and technologies that have proven to be promising or essential for constructing Digital Twins. Corresponding related research questions are:

RQ-3.1 *How are Digital Twins implemented?* There might be different possibilities for realizing Digital Twins. This question aims at exploring these.

RQ-3.2 *Which tools are used to engineer Digital Twins?* In addition to the method of implementation, we are also interested in which tools are used during development. With this question, we aim to investigate whether there are certain trends concerning the tools used for the Digital Twin implementation.

RQ-3.3 *Are Digital Twins developed with their own development process or are they developed together with the observed entity?* Since the term twin already suggests a strong similarity to the observed system, we leverage this question to further investigate how this similarity affects the development process of Digital Twins.

RQ-3.4 *How is quality assurance for the Digital Twin supported?* With this question, we want to explore whether Digital Twins use the same or different methods for quality assurance than the observed system.

RQ-3.5 *Has the Digital Twin own requirements?* Like most systems developed using engineering methods, a Digital Twin might have requirements to fulfill. With this question, we intend to investigate whether and to which extent such requirements are already considered during the development of Digital Twins.

4. How are Digital Twins deployed?

After their construction, Digital Twins must be deployed appropriately. This research question investigates the initial configuration and system environment of twins. Furthermore, we consider concrete technologies for interconnectivity, resulting in the following research questions:

RQ-4.1 *Where is the Digital Twin deployed?* This question aims at uncovering whether Digital Twins operate in the cloud, on the edge, directly on the twinned system, or somewhere else.

RQ-4.2 *How are Digital Twins connected to the observed entity?* Digital Twins can be connected to their counterpart to exchange information. With this question, we want to find out which technologies are used to connect them.

5. How do Digital Twins operate?

Finally, we analyze the operation of Digital Twins, including in- and output, as well as underlying data structures. Furthermore, we investigate the possibilities of current Digital Twins to autonomously perform decision-making. Hence we investigate the following research questions:

RQ-5.1 *Does the Digital Twin feature decision-making functions?* A probable use case for Digital Twins can focus on its application to make decisions for a system. With this question, we aim to identify the different approaches to realize these artificial decision-making processes.

RQ-5.2 *To which events, inputs, or data does a Digital Twin react to?* Digital Twins usually rely on information about the physical entity's state and user inputs. With this question, we identify how the Digital Twin gains required information and which events trigger its actions.

RQ-5.3 *Which output does it produce?* A frequent use case of Digital Twins is representing the physical entity's state. With this question, we aim to find out how Digital Twins interact with their environment and how they communicate to and influence their operating context.

6. How are Digital Twins evaluated?

We analyze how the included publications evaluated their contributions. For quantification, we identify and assign classes of the different technology readiness levels. Furthermore, we explore whether the publications provide any metrics related to the proposed Digital Twins that could be reused in future research.

RQ-6.1 *Which technology readiness levels do Digital Twin evaluations employ?* When constructing Digital Twins, there can be a vast range between how the results are evaluated and to which extent they are ready for application in an industrial context. Thus, this question aims at classifying how mature the proposed twins are.

RQ-6.2 *Does the Digital Twin yield any measurable advantages?* As their deployment comes with a specific goal of what Digital Twins can achieve or improve, this question investigates potential benefits.

3.2. Search Queries and Data Sources

The search strategy is of major importance for the identification of relevant publications in order to answer the research questions. In order to do so, formulating an appropriate search query and selecting the relevant libraries is required. As we aim to find out who uses Digital Twins independently of a concrete domain or application context, we do not restrict our search term any further. Therefore, we ultimately searched in the selected databases for "Digital Twin", keeping the search query simple and pragmatic. The selected databases are ACM Digital Library, IEEE Xplore, Scopus, SpringerLink, Web of Science. We opted to omit Google Scholar due to its problems with structured literature retrieval [382] and to ensure quality of included sources.

As we conducted a full-text search for "Digital Twin", we omitted using other related terms, such as "digital thread" or "digital shadow" as we expect publications contributing to Digital Twin research should at least use this term in either related work or referenced literature. However, we cannot guarantee to not miss a small amount of relevant publications, but argue that searching this way seems more appropriate than just searching in titles and abstracts for keywords. Moreover, we also did not put any lower bound as year limit and included papers published until October 2019. We extracted the results as comma-separated lists and manually merged these into a single list of unique publications.

3.3. Screening Publications

The inclusion of a study into the classification phase of a systematic mapping study usually is decided based on its quality and accessibility as well as on its title, abstract, and keywords [386]. To reduce the corpus and enable reproduction of the study, we used the following explicit inclusion and exclusion criteria.

Inclusion criteria. From the initial corpus we identified the potentially relevant publications based on the following four criteria:

1. Studies published in peer-reviewed sources namely journals, conferences, and workshops.
2. Studies are electronically accessible.
3. Studies are available in English.
4. Studies where we could deduce from title, abstract, or keywords that their main topic of study is the conception or application of Digital Twins.

Exclusion criteria. Publications fulfilling the inclusion criteria were still excluded based on the following four criteria:

1. Studies from sources without systematic peer-review processes, such as books, magazines, and websites.
2. Short papers of less than 5 pages excluding references, such as editorials, reviews, or tool demonstration teasers.
3. Studies where Digital Twins are related work, further applications, or a broader context only.
4. Studies presenting literature reviews on Digital Twins (which are already discussed in Section 2).

While we did not limit the search to any time frame, the final corpus considered relevant does not include any papers from before the year 2011. This is due to the term only then gaining popularity and contributions not meeting our inclusion criteria.

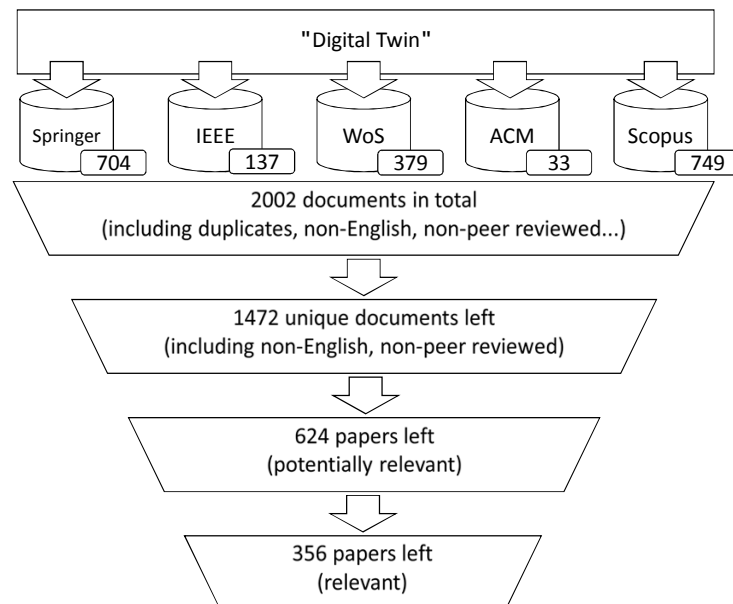

Figure 2: Data collection initially produced 1472 unique documents, out of which 356 were identified as relevant for our study.

We each analyzed and classified the first 30 (about 2%) publications of the 1472 unique publications of the corpus to build a shared understanding of Digital Twins, the research questions, and the classification scheme. We then discussed the analysis results to align our understanding of the publications, our analyses, and the research methodology.

To filter publications based on unambiguous exclusion criteria, we evenly distributed the remaining 1442 publications. Afterward, we determined inclusion based on whether a publication's main contribution is towards Digital Twin research by screening titles, abstracts, and keywords only. We delayed the inclusion decision to the classification phase for publications where abstract and title screening did not suffice to determine inclusion. In this classification phase, we then decided the inclusion based on the publications' full text to not exclude relevant publications with sub-optimal phrasing of abstract or title.

Eliminating 530 duplicates and 848 publications outside the scope of our study left 624 publications for review. These publications were again distributed between the authors of this paper for a detailed review and classification. Furthermore, we discussed the classification, exclusion, and inclusion of publications to align and refine our understanding whenever needed. During these discussions, we excluded additional publications and refined our shared understanding of the classification scheme. During the reviews and discussion, further unrelated publications were excluded. However, we did not exclude publications based on their venue or comprehensibility alone, and we also did not perform any additional quality evaluations.

3.4. Classification Schema

To investigate Digital Twins appropriately, we have developed a corresponding classification scheme. This scheme is inspired by [386] and adapted for the landscape of Digital Twin research. The specific facets are based on our research on digital twins (e.g., [357, 360, 358, 359]) and have been revised and/or refined iteratively while discussing the papers among the authors as well as with digital twin experts of the "Internet of Production"⁴ excellence cluster and the "Christian Doppler Laboratory for Model-Integrated Smart Production"⁵.

After the initial screening, we analyzed the remaining 624 potentially relevant papers in the classification phase. We have read the remaining papers completely to extract all relevant information and excluded publications that turned out to be irrelevant for Digital Twins. We categorized the 356 remaining papers as follows.

Contribution Type Facet. Distinct papers may include different facets of contribution. Thus, inspired by [386], we classified the publications for the type of contribution. By this means, we used five contribution types [386] to examine the overall kind of benefit the analyzed papers provide:

- *Analyses*: Papers presenting investigations without constructive contributions, e.g., [76, 178, 186].
- *Concepts*: Papers presenting ways of reasoning about things, such as new metamodels or taxonomies, e.g., [1, 99, 207].
- *Methods*: Papers presenting ways of doing things, e.g., [4, 19].
- *Metrics*: Papers presenting ways of measuring things, e.g., [32, 264, 333].
- *Tools*: Papers presenting novel software tools related to implementing Digital Twins, e.g., [12, 24, 88].

We classified each publication uniquely to a contribution type.

Research Type Facet. A further important question relates to the research type of elaboration. It describes how the findings are conducted and presented. Again inspired by [386], we further distinguished the publications by their research type. We adjusted the originating classes to better match our corpus, e.g., by excluding philosophical facets, as these did not occur in our study. The five resulting research types based on [386] are:

- *Evaluation*: Papers evaluating existing techniques, cf. e.g., [51, 81, 130].
- *Experience*: Papers reporting personal experiences, e.g., [24, 71, 73].
- *Solution*: A novel solution is presented and argued for with case studies, e.g., [1, 11].

⁴Internet of Production website: <https://www.iop.rwth-aachen.de>

⁵CDL-MINT Christian Doppler Laboratory website: <https://cdl-mint.se.jku.at>

- *Validation*: Papers presenting novel techniques and experimenting with them, e.g., [50, 52, 103].
- *Vision*: Research agendas, e.g., a vision of model-based logistics engineering presented in [5, 18].

These five facets provide an overview of the research focus of the analyzed papers. The classification was disjoint, and we discussed contributions when in doubt.

RQ-1.1 - Digital Twin Application Domain Facet. When considering the application domains of Digital Twins, smart manufacturing often comes to mind first. To better understand why this is the case and which domains employ Digital Twins, we investigate **RQ-1.1**. To classify the different domains, we employed the Level 1 classes of the Statistical Classification of Economic Activities in the European Community [388], which comprise all economic areas currently considered by the European Parliament. Consequently, the application domain facet of our survey comprises all 20 level 1 classes specified below:

- *A* - Agriculture, Forestry and Fishing
- *B* - Mining and Quarrying
- *C* - Manufacturing
- *D* - Electricity, Gas, Steam and Air Conditioning Supply
- *E* - Water Supply, Sewerage, Waste Management and Remediation Activities
- *F* - Construction
- *G* - Wholesale and Retail Trade; Repair of Motor Vehicles and Motorcycles
- *H* - Transportation and Storage
- *I* - Accommodation and Food Service Activities
- *J* - Information and Communication
- *K* - Financial and Insurance Activities
- *L* - Real Estate Activities
- *M* - Professional, Scientific and Technical Activities
- *N* - Administrative and Support Service Activities
- *O* - Public Administration and Defense; Compulsory Social Security
- *P* - Education
- *Q* - Human Health and Social Work Activities
- *R* - Arts, Entertainment and Recreation
- *S* - Other Service Activities
- *T* - Activities of Households as Employers; Undifferentiated Goods and Services Producing Activities of Households for Own Use
- *U* - Activities of Extraterritorial Organizations and Bodies

Where the research is generic to an application domain, it is classified as “J -Information and Communication”. We have chosen this category because Digital Twins are fundamental software systems. Contributions that do not address a specific application domain therefore describe general information and communication systems for the application of Digital Twins. Leveraging this classification scheme, we applied a single application domain to each publication.

RQ-1.2 - Purpose Facet. Digital Twins usually exist not only for their own sake, but to fulfill a specific purpose concerning their physical counterpart. Concerning **RQ-1.2**, we aimed to understand these purposes and therefore differentiated between the following dimensions:

- *CPS Data Processing, Integration, Persistence* summarizes purposes related to data processing, integration, and persistence checking, such as knowledge collection [6], privacy enhancement [18], or data integration into a shop floor environment [272].
- *CPS Maintenance* subsumes purposes related with maintaining a CPS, such as predictive maintenance [183], fatigue testing [103], or damage evaluation [60].
- *CPS Monitoring* describes purposes related to collecting, analyzing, and visualizing data about the state of a Cyber-Physical System (CPS), such as real time monitoring of building operation efficiency [100], health monitoring [318], or process parameter monitoring [277].
- *CPS Behavior Prediction* summarizes purposes to predict future CPS behavior, such as fuel consumption prediction [95], driver behavior prediction for crash analysis [104], or predict pulsation and velocity inside the vessel of a human heart [245].
- *CPS Behavior Optimization* subsumes purposes related to optimizing a CPS’s behavior, such as path planing for robots [24], running mode optimization of CNC tools [122], or reduce fatigue damage [296].
- *CPS Validation* describes purposes related with verification and validation activities, such as structural integrity analysis [282], damage modelling for automotive low-carbon structural steel validation [98], or robot algorithm validation [188].
- *CPS Reuse* describes purposes related to CPS reuse, such as design reuse [336], or reconditioning [148].
- *Design Space Exploration* subsumes purposes in the context of design space exploration, e.g., variation analysis [330] or virtual prototyping [260].
- *Enterprise decision making* summarizes purposes that evolve around complex enterprise processes and decision making, such as macro perspective analysis [107], or smart process planing [138].
- *Teaching* describes the purposes related to initial and continuing education, such as manufacturing machine exploration [228], teaching of manufacturing cell handling [241], or robot manipulation training [343].
- *Visualization & Representation* summarizes purposes directly related to visualizing a physical counterpart, such as represent a production site in a virtual environment [7], or visualizing object properties in augmented / mixed reality [169].

Since Digital Twins might have more than one purpose, e.g., the health monitoring the approach presented in [318] relates to monitoring as well as maintenance, the selection mentioned above is not disjoint.

RQ-2.1 - Counterpart Facet. A Digital Twin is little without its counterpart. To better understand what it is that is “twinned”, we classify our corpus’s publications according to the various counterparts described. Our classification schema of Digital Twin counterparts comprises:

- *Biological Beings*, such as factory employees [215], fishes [266], or sports players [288].
- *Individual Systems*, such as automated cars [219], gas turbines [108], or manufacturing machines [67].

- *Processes*, e.g., business processes [77], medical processes [273], or recycling processes [239].
- *Products*, such as reinforced plastics [330], sunroof ring frames [210], or wearable masks [40].
- *Systems of Systems*, such as complete factories [1], oil wells [131], or railway systems [207].
- *Other counterparts*, e.g., arbitrary physical bodies [162] or unspecified manufacturing resources [291].

To distinguish whether a publication reports on an individual system, product, or system of systems, we discussed these publications and together decided about their specific focus regarding the Digital Twins' counterpart(s). We also encountered some publications that report on Digital Twins for more than one counterpart or a combination of counterparts, such as processes and related systems of systems [85] or products and related systems [348]. Such contributions add to multiple counterpart facets accordingly.

RQ-2.3 - Digital Twin Lifetime Facet. Digital Twins can reflect, monitor, and support all phases of the physical entity. In some application scenarios building the physical entity may be very time- or cost-intensive. In these cases, a Digital Twin can be applied during the design phase of the physical entity to communicate design decisions or to simulate multiple designs. At runtime, a Digital Twin may monitor the physical entity's actions and suggest further steps, e.g., for minimizing raw material waste or energy consumption. Consequently, we introduce a Digital Twin lifetime facet that distinguishes:

- *Design-time*, to characterize Digital Twins that are employed during the the design phase of the physical entity, e.g., to evaluate different product variants [219].
- *Runtime* to characterize Digital Twins that are employed while the physical entity is already operating. These Digital Twins may predict future behavior or control and optimize the physical entities' next steps [19].

Whether a publication describes a Digital Twin that is used at design- or runtime was usually explicit. In cases where a reviewer could not classify the described Digital Twin, we also discussed the respective paper among the authors. We also encountered publications that report on Digital Twins for more than one lifetime or even Digital Twins that were transferred from design- to runtime [20]. Such contributions add to multiple lifetime facets accordingly. In contrast to **RQ-2.4** this question focuses on the lifetime where the Digital Twin is applied and not on the lifecycle step for which the Digital Twin reflects the physical system.

RQ-2.4 - Digital Twin Lifecycle Facet. Digital Twins application scenarios can be distinguished along the system's lifecycle specified in the ISO/IEC 15288 system lifecycle [389]. This norm distinguishes roughly three product lifecycle phases: the design phase including the conceptualization and modeling of the system, the manufacturing phase where the system is brought into existence, and the operation phase where the system operates and fulfills its intended purpose [405].

Depending on the twinned system's lifecycle phase, Digital Twins serve different purposes [403]. For instance, Digital Twins might represent a system as it is designed for design-space exploration of that system before it is constructed or Digital Twins focus on the running system as it is in use to represent its current state and serve for the maintenance prediction. Consequently, we introduce a Digital Twin lifecycle facet that distinguishes:

- *As-Designed*, to describe Digital Twins that represent the physical counterpart during its design phase. These Digital Twins are e.g., useful for optimizing the production process [16].
- *As-Manufactured* also integrates data that characterizes the manufacturing process of the physical counterpart. Thus, it may include runtime data that provides insights for maintenance [314] or predicting material fatigue [41].
- *As-Operated* describes Digital Twins that represent the usage and operation of the physical counterparts, e.g., for supervising and optimizing [56, 53] or for predicting future behavior [29, 31].

To distinguish whether a publication describes a Digital Twin as designed, manufactured, or used, we discussed the categories a-priori in detail. If case a reader could not classify the described Digital Twin we also discussed the respective paper among the authors. We also encountered publications that report on Digital Twins for more than one lifecycle [353, 402]. Such publications contribute to multiple lifecycle facets accordingly. In contrast to **RQ-2.3** this question focuses on the lifecycle stage the Digital Twin represents and on the time when the Digital Twin is used.

RQ-2.5 - Interaction Facet. Literature exhibits various understandings of Digital Twins from precise models used at system-design time [5, 8, 16] that are used to prescribe a system to be to software systems twinning another system and directly manipulating its behavior [176, 213, 253]. With this facet, we, thus, investigate whether Digital Twins tend to support direct interaction with the observed system. To this end, we distinguish two cases:

- *Direct Interaction* comprises Digital Twins that are directly connected to their counterpart through various communication measures, such as message busses, networks, or Internet technology.
- *No Direct Interaction* describes Digital Twins in which interaction either is indirect, e.g., by informing a human operator to execute system manipulation or there is no interaction at all, such as where the Digital Twin is interpreted as a dataset recorded from the twinned system.

Each publication contributes to exactly one of these classes.

RQ-2.6 - Optimization Facet. Many Digital Twins seem to optimize either themselves, their real-world counterpart, or both. However, not all Digital Twins strive to optimize. With this facet, we aim to investigate whether the optimization is considered in the development of Digital Twins and whether the Digital Twin optimizes itself, or its real-world counterpart. In our classification schema we, therefore, distinguished as follows:

- *Digital Twin Optimization* incorporates Digital Twins which optimize themselves without aiming to influence their twinned entity directly with this optimization. In [329] for example, the Digital Twin collects data from a health monitoring system to optimize its structural health model of the real-world counterpart.
- *Counterpart Optimization* subsumes Digital Twins aiming to only optimizing their real-world counterpart. For instance, in [137] a Digital Twin is initialized with real tech parameters and then used to optimize the real-world counterpart, without updating the Digital Twins simulation model.
- *Digital Twin & Counterpart Optimization* subsumes Digital Twins that not only optimize their counterpart alone, but also use information from their counterpart to optimize themselves. In [250], for example, the Digital Twin is used for state estimation in non-linear electro-mechanical systems and optimizes not only the electro-mechanical system but also the Digital Twin itself.

Of course, we also encountered multiple publications where counterpart or self-optimization was explicitly not the purpose of the Digital Twin concept, as they focused on visualization [59] or monitoring [90] alone. Moreover, some authors decided not to mention the possibility that the Digital Twin performs such optimization at all as, e.g., in [198]. However, as we cannot differentiate between publications where optimization is thought of as irrelevant for the purpose of Digital Twins and publications where the optimization was just not relevant for the published aspect, we decided to subsume these papers in an additional category.

RQ-2.7 - Digital Twin Parts. A Digital Twin usually is a logical unit, which is composed of different parts. For example, we can distinguish between data, services, a virtual models and physical entities [406]. To understand how Digital Twins are developed and which components are necessary for software to become a Digital Twin, we collected information about Digital Twin parts.

- *Data* describes live data about the physical entity [11], historical data about the physical entity [26], or data from other data sources that provide contextual information about the application scenario of the physical entity [95].
- *Hardware Components* captures Digital Twins, which also contain physical components, such as equipment [350].

- *Models* describes software artifacts that are classified as models according to Stachowiak [404], i.e., they have a purpose, perform abstraction and have a physical entity. Frequent examples were simulations [3] and CAD models [33]. We further classified models according to the aspects they describe. Thus we identified
 - structure of the physical twin, e.g., inner components,
 - behavior of the physical twin, e.g., interaction with its environment,
 - appearance of the physical twin, e.g., material information, and dimensions,
 - constraints of the physical twin, e.g., physical laws.
- *Software Components* characterizes custom [152] and external [272] software services that are described as part of the Digital Twin and cannot be classified as models.

Where publications ambiguously define which components they consider as part of the Digital Twin, we decided in favor of including these components as parts of the Digital Twin. In cases where no categorization was possible, we discussed the papers between us until we could reach an agreement. Many Digital Twins consist of multiple components, which can be assigned to different facets. These publications contribute to several facets.

RQ-3.1 - Implementation Technique Facet Digital twins are created using various implementation techniques depending on their purpose, lifetime, and more. With **RQ-3.1**, we analyze the different facets in which they are realized, including various models, programming languages, or simulations. Thus, we identified the following classes.

- *CAD/3D Models* describing the geometric representation of a physical component [1].
- *Data and Databases* covering collecting and analyzing operation data [328] as well as different data formats [352].
- *General Purpose Languages*, such as Java [144], C++ [76], and Matlab [44].
- *Mathematical/ Physical Models*, such as finite element [128] and multi-physics models [309].
- *Model-Driven Engineering (MDE)*, such as UML or SysML models [289], language workbenches [87], and AutomationML [120].
- *Simulation and Analysis*, such as Simulink [121], Verosim [188], or AnyLogic [299].

The selection is not disjoint as contributions may use particular techniques as a foundation for implementing Digital Twins. For instance, [128] combines geometric data with physical models, which contribute to the construction of the system.

RQ-3.2 - Tooling Facet. Engineering Digital Twins of different counterparts and for different purposes efficiently demands corresponding tool support. With this facet, we aim to uncover which kind of tools are used in the development and operations of Digital Twins. Our classification schema regarding tools applied to the engineering or operations of Digital Twins comprise tools that were mentioned 7 or more times by the publications of our corpus:

- *Artificial Intelligence Software*, such as Apache MXNet [95], the IBM Watson software development kit [218], or TensorFlow [256].
- *Communication Software*, including ROS [236], OPC UA [148].
- *Computer-Aided Design (CAD)* and 3D modeling, such as SolidWorks [7], Siemens NX [45], or Autodesk Revit [129].
- *MDD Software*, such as AutomationML [325], Modelica [159], or SysML [176].
- *Data Management Software*, such as Apache SOLR [344], SQL databases [100], or SAP HANA [214].

- *Process Management Software*, including ChemSiemens10 Tecnomatix [160], UniSim Design [53], or in-house developed solutions [355].
- *Product Lifecycle Management Software*, such as Siemens PLM [45].
- *Programming Languages*, including Python [124], Java [144], and others.
- *Simulation Software*, such as Abaqus [279], Gazebo [57], the MAYA simulation framework [25], or Verosim [50].
- *Visualization Software*, such as Unity [104], OpenCV [36], or APIs for augmented reality devices [60].
- *Other Software*, including various programming languages [294], specific self-developed toolsets [316], APIs for communication [3], or website development tools [248].

Some contributions use the same software, such as MDE software or the various programming languages for multiple purposes and employ a wide variety of software to engineer or operate Digital Twins. Consequently, our classification schema for the tooling facet allows for more entries than the number of publications included in the corpus.

RQ-3.3 - Digital Twin Engineering Process Facet. Digital Twins can be developed before the twinned system, together with it, or after it. Developing the Digital Twin before the twinned system can facilitate design space exploration by frontloading of the twinned system as the Digital Twin might be used as substitute to explore properties of the twinned system at higher levels of abstraction. Developing the Digital Twin together with the observed system enables optimizing their interaction by, e.g., joint design-space exploration of both, the Digital Twin and the twinned system. Developing the Digital Twin after the twinned system enables adding advanced functionality to existing systems and makes these accessible for analyses typically related to Digital Twins, such as behavior prediction. To better understand whether Digital Twins are generally developed together with their counterparts or detached from them, we have grouped the publications of our study accordingly. Our classification scheme of the development process of Digital Twins, thus, includes the following categories:

- *Joint Engineering* incorporates publications where the engineering and the evolution of Digital Twins are intertwined with the engineering of their counterparts.
- *Subsequent Engineering* incorporates publications where the engineering of the Digital Twin i.e., the process itself, succeeds the engineering of their counterpart. Here, the counterpart to be twinned, or previous versions of it, already exists, and that this information about the counterpart can be leveraged for its twinning.
- *Explorative Engineering* means that the development of the Digital Twin frontloads the development of their counterpart. Here, Digital Twins are developed from scratch without including information about their existing counterpart. Instead, they can be used to explore the properties of their counterpart.

We encountered some publications reporting that Digital Twins can be engineered in both fashions, either in a joint process together with their counterpart or in their own process independent of the engineering process of their counterpart. Of those publications that reported that a Digital Twin has its own engineering process, only some clarified if the Digital Twin was to be developed before or after the system. If a publication did not report on the engineering process of Digital Twins, or if that information was not derivable from the purpose of Digital Twins, then we regarded corresponding information as not available.

RQ-3.4 - Quality Assurance Facet. The Digital Twin can be understood as a precise design-time model, e.g., used for design space exploration of the system under development, prediction of its future behavior, and general frontloading, or as a software system observing another system at the other system's runtime. Consequently, different means of quality assurance need to be employed to produce, operate, and maintain a high-quality Digital Twin. Concerning **RQ-3.4**, we aim to understand the state of quality assurance for Digital Twins. Our classification schema of Digital Twin quality assurance comprises the following dimensions:

- *Consistency monitoring*, e.g., by monitoring the differences between Digital Twin predictions and data obtained from the twinned system at its runtime [136, 76].
- *Simulation*, used at system design-time [5, 147].
- *Testing* other than simulation [244], also employed at design time.
- *Other verification*, such as model-checking, also applied at design time [27, 247].

As the boundaries between simulation, testing, and other verification are not used strictly through our corpus, we followed the terminology employed by the respective authors.

RQ-3.5 - Requirements Facet. Like any engineered system, Digital Twins are likely to have certain requirements to meet. So we addressed the question of whether Digital Twins have requirements of their own and considered the requirements that are typically placed on Digital Twins. To this end, we identified the following facets based on the publications in our corpus:

- *Real-time capability* requires from the Digital Twin that it provides its services or responses within a specified time constraint as e.g., required in [5, 214].
- *Digital Twin reaction matches real-world behavior* subsumes various verification and validation requirements aiming to ensure that the behavior of the observed system meets the reaction of the Digital Twin [336].
- *Reusability* requires the Digital Twin to be reusable in different contexts or for closely related systems [336, 231].

As no other facet was mentioned more than once in the publications of our corpus, we decided not to further investigate these possible facets.

RQ-4.1 Digital Twin Host Facet. A Digital Twin may operate in some context, such as in some cloud, on an edge device, or directly on the twinned system. To understand where Digital Twins operate we classify the publications in our corpus according to the various hosts described:

- *Cloud* incorporates publications where the Digital Twin is deployed in some cloud, either named or non-specific [19].
- *Fog* means that the Digital Twin is deployed on another device than its counterpart but still resides in a local network [294].
- *Edge* when the Digital Twin is deployed on the same device as its counterpart [44].

This facet also includes data regarding Digital Twins host of unspecified provenance with respect to the hosting alternatives above but on the kind of system hosting the Digital Twin:

- *Data Management System* if the host of the Digital Twin is a database or some other data-centric application [152].
- *Simulator* incorporates Digital Twins that are employed as part of a simulation, such as 3D simulation models [148].
- *Virtual Reality* for Digital Twins deployed in a virtual reality [304].

Reported findings describe the hosts' location, such as in the cloud, on an edge device, or directly on the twinned system; or describe the host's kind, including data management systems, simulations, and virtual reality. As such, we encountered publications with multiple findings in this facet, e.g., if the Digital Twin was deployed on some database in the cloud. But also findings with multiple reports of the host's location where possible, in cases where Digital Twin could be deployed either in the clouded or some local system.

RQ-4.2 Digital Twin Counterpart Connection Facet. As Digital Twins seem to be connected with their real world counterpart, we investigated in the context of **RQ-4.2** which technologies are used to connect the Digital Twin with its real world counterpart. To understand these connections we classify the used technologies as follows. First, we identified a set of hardware or technology related connections that were often described in our corpus:

- *Local Networks* connect Digital Twins by establishing BUS systems [5], Ethernet [16] or WiFi [122].
- *Short distance wireless communication* subsumes non-LAN short distance communications, such as RFID [10] or Bluetooth [216].
- *Data* connect Digital Twins with their counterparts by its data as for example described in [83] which use a database.
- *Server/Cloud/Proxy* in this connection type the Digital Twin is connected with the real world counterpart based on a remote server such as a cloud application [292].

On the other hand, we also found connection descriptions that solely focus on the used communication protocol:

- *Industrial protocols*, such as MTConnect [252] or OPC UA [235].
- *Internet protocols*, such as TCP/IP [4], UDP [177], or HTTP [89].
- *IoT Protocols*, such as [90].

Of course, not all publications of our corpus strictly differentiate between the communication technology and the protocol. Thus, multiple selections were possible.

RQ-5.1 - Decision Making Facet To influence the observed entity, a Digital Twin should be able to make decisions based on its counterpart's current state and condition. Thus, we distinguish in **RQ-5.1** between the following classes of decision-making functions to better understand the nature of these decisions.

- *Data Mining*, such as big data methods [146], or data cleansing techniques [53].
- *Machine Learning*, such as artificial neural networks [89], or deep learning [95].
- *Reasoning* techniques, further distinguished into
 - *Case-based Reasoning*, e.g., [151].
 - *Symbolic Reasoning*, such as [50].
 - *Stochastic Reasoning*, for instance [22].
 - *Other Numeric Reasoning*, classifying remaining methods such as [136].
- *Simulation*, such as finite element analysis [8], virtual testbeds [72], or rigid body dynamics [74].

As some contributions employ multiple decision-making functions for their Digital Twins or use combinations of different techniques, these classes are generally not disjoint. For instance, in [97], the Digital Twin uses a data mining to process gathered data and furthermore simulates values that could not be obtained from the physical counterpart. If a publication did not explicitly specify any corresponding functions, we classified the Digital Twin to offer no decision-making functionality.

RQ-5.2 - Digital Twin Input and Events Facet. Digital Twins rely on specifications that define how the Digital Twin should behave in different situations, e.g., when context changes occur, when external inputs are given, or when the equivalent acts in a certain way. Inputs for Digital Twins have different sources, as humans that explicitly control the Digital Twins' actions or models that specify the Digital Twin's behavior. Digital Twins also react to events that occur in their operating context or in the physical entity that they represent. We introduce the input facet to classify the input data that the Digital Twin relies on upon and differentiate between different input data sources as follows:

- *Machine Data* specifies all data captured by sensors [6] or emitted by machines [15].
- *Models and Simulations* includes data that is provided by simulations [25] or specified through models [106].
- *User Specifications* characterizes all Digital Twins that are configured via direct user input, e.g., through a user interface [16] or motion capturing [179].

For the papers where a description was given, this facet could generally be identified unambiguously. However, in some cases, it was not reported how the DT was configured. We did not assign a facet to these papers and classified these as non-assignable.

RQ-5.3 - Digital Twin Output Facet. Digital twins that fulfill some kind of purpose other than modeling their counterpart often interact with their environment through inputs and outputs. Outputs can take different forms and have various intentions. To better understand what kind of outputs Digital Twins can produce, we have grouped the contributions according to the following schema:

- *Observations*, if the Digital Twin represents the current state of the twinned system, i.e., monitoring data.
- *Prescriptions*, for Digital Twins emitting instructions sent by the digital twin about changes that should be applied, incorporating parameter configuration changes, detailed control commands, and planning data.
- *Predictions*, when the Digital Twin produces predictions or estimations about the system behavior, failures, and life expectancy, i.e., what can be.
- *Other Data*, when Digital Twins output data but the nature of this data is not further specified.
- *Visualization & 3D Models*, when the output of Digital Twins are changes to a UI or 3D models for visualization of their counterpart.

As these categories overlap, publications may be assigned multiple times.

Generally, contributions reported that the output of Digital Twins can represent the current state of the system, contain predictions or estimations, or describe changes and modifications that should be applied. In some cases, the output of Digital Twins was described as less detailed, only stating that Digital Twins emit some kind of analysis result or some kind of data. Also, some contributions reported visualization of Digital Twins through a UI or 3D models as an output of Digital Twins. If a publication did not explicitly report outputs for Digital Twins, then we regarded the corresponding information as not available.

RQ-6.1 - Digital Twin Evaluation Maturity Facet. Digital Twins are expected to improve our understanding and use of systems. To understand how mature the research results within our corpus are, we classify their contributions according to the technology readiness level (TRL) [381] of their evaluations or case studies. As publications rarely can provide fully detailed evaluations due to, e.g., page limitations or confidentiality considerations, a precise estimation of evaluation maturity is rarely possible as well. Hence, we classify evaluation maturity as follows:

- *Proof of Concept* (TRL 1-3), includes evaluations in which at least basic principles of the research can be observed and at most an experimental proof of concept is reported.
- *Technology* (TRL 4-6), includes evaluations where technology is at least evaluated in a laboratory context and at most in a relevant environment.
- *System* (TRL 7-9), includes evaluations in which at least a system prototype is demonstrated in an operation environment.

Each publication was assigned a single TRL.

4. Vertical Analysis

During the vertical analysis, we aim to provide quantitative results for all research questions, where an answer for this research question without considering other research questions was possible. In the following subsections, we present the results of this analysis for our questions. As not all research questions could be answered unambiguously or with sufficient significance based on the publications in our corpus, observations and potential insights to these research questions are briefly revisited in the discussion.

4.1. Contribution Type

The papers in our corpus address various topics and represent different types of contributions. Accordingly, we classify the publications in our study by their type of contribution [386]. The classified contribution types are disjoint, and thus, each publication was classified to exactly one contribution type. Publications suitable to more than one contribution type were classified to the most suitable.

Overall, the majority of contributions address methods (223, 62.64 %) or concepts (98, 27.53 %), whereas contributions mainly addressing tools (19, 5.34 %), analyses (13, 3.65 %), or metrics (3, 0.84 %) are considered far less often. The distribution of contribution types is shown in Figure 3.

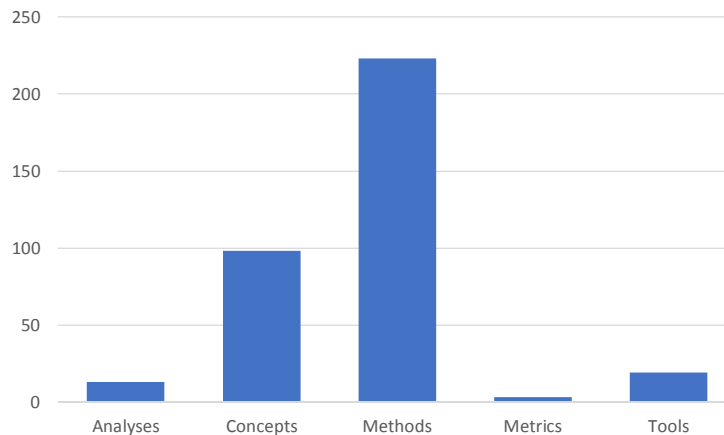

Figure 3: The contribution types of included publications

The major focus on concepts and methods and the lack of analyses may be a symptom of the still young field of research on Digital Twins. Research and industry have not advanced enough, and exhaustive solutions employing Digital Twins exist whose effect could be analyzed in detail. Surprising is the lack of tooling, which would be needed to employ Digital Twin solutions. While some contributions on metrics for Digital Twins exist, most of these are employed in a broader research concern, with only a few publications focusing on metrics in particular. Focusing research on tooling for Digital Twins realizing the presented concepts and methods could move research on Digital Twins forward in the future.

4.2. Research Type

Besides the contribution type, we also analyzed the publications research type and classified the publications according to the schema presented in Section 3.4. Again, each paper was classified to exactly one research type, that is to the most suitable research type if a paper was eligible for more than one category.

We found that solution proposals are the most common research type in Digital Twin research, which make up 233 (65.45 %) of all publications in our corpus. Other research types are far less common. Out of the 356 publications in our corpus, vision papers only contribute 59 (16.57 %), experience reports only 37 (10.39 %), evaluation reports only 16 (4.49 %), and validation papers only 11 (3.09 %) publications to the overall corpus. The distribution of research types is shown in Figure 4. It is similar to the distribution of the classification of contribution types in the sense that two-thirds of the publications also contribute to a single class.

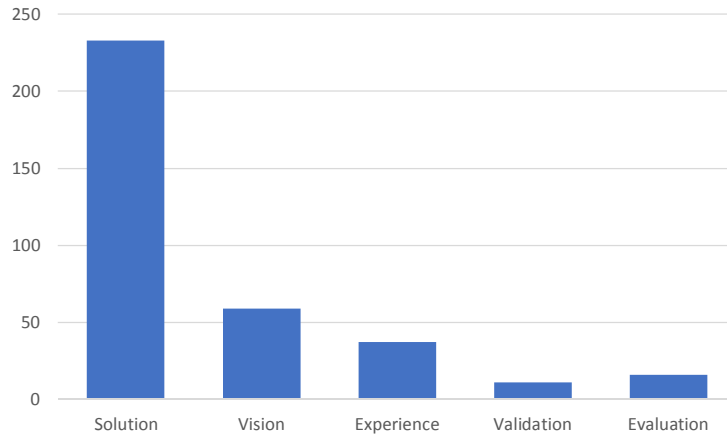

Figure 4: The research types of included publications

A similar distribution of research and contribution types might reflect constructive research on Digital Twins, which is reinforced in particular by the large number of publications describing solutions. Despite the many papers describing methods or concepts, there are only a few publications that focus primarily on validation. One of the upcoming goals in Digital Twin research should be to validate and evaluate existing approaches and solutions in detail.

4.3. *RQ-1.1 - Digital Twin Application Domains*

While manufacturing and Industry 4.0 might come to mind first, when considering the application domains of Digital Twins, there are plenty of other domains Digital Twin research is applied to. By classifying the studies according to the schema presented in the corresponding facet, we identified eight domains that research on Digital Twins focuses on. The domains, together with the number of publications addressing these, are illustrated in Figure 5.

All 356 (100 %) publications of our corpus relate to a specific domain or contribute to generic research on Digital Twins. The large majority of research on Digital Twins focuses on (C) manufacturing (252, 70.79 %) and on (J) Information and Communication (47, 13.2 %). The remaining (16.01 %) publications are almost equally split into further domains and generic Digital Twin research. Of the other domains, (D) energy (17, 4.77 %) and (F) construction (12, 3.37 %) are more often addressed than (Q) human health (8, 2.25 %), (B) mining (9, 2.53 %), or (H) transportation and storage (6, 1.68 %). We also found publications conducting research on Digital Twins for (P) education (4, 1.12 %) and (A) agriculture (1, 0.28 %). For the other twelve classes of economic areas, we did not find research on Digital Twins.

This especially holds for areas where digitalization and automation might not be as advanced as in manufacturing, such as (E) water supply and sewage, (G) wholesale, (I) accommodation and food service activities, (L) real estate activities, or (R) arts and entertainment. This maybe be because they do not need a Digital Twin, use different terminology, or we have simply missed publications as they are not indexed by our databases or the people involved do not publish their results in scientific literature. Many of the areas not addressed by publications in our corpus also are areas in which human actions and decisions are central to creation of added value, such as wholesale, accommodation, financial activities, real estate activities, public administration, arts and entertainment. The lack of publications addressing these might be a symptom of properly capturing Digital Twins of human actors, which is in line with the small number of Digital Twins of beings as observed regarding **RQ-2.1**.

4.4. *RQ-1.2 - Digital Twin Purpose*

One question any application of new concepts, methods, or tools are faced with is their purpose. Thus, we analyzed which purposes Digital Twins fulfill. Based on the classification scheme presented in the corresponding facet, we aimed to answer **RQ-2** and concluded how many publications mention a purpose and how these purposes distribute over the purpose facets. Of our corpus (356, 100 %), 347 (97.47 %) publications make the purpose of the

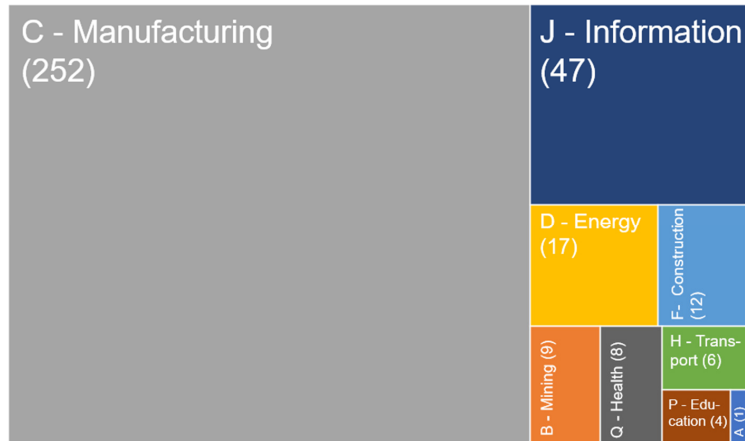

Figure 5: Application domains of Digital Twins

Digital Twin explicit. Consequently, a majority mention the purpose of the Digital Twin explicitly, which distribute over these purposes as illustrated in Figure 6. Moreover, we found out that most Digital Twins have more than one purpose (196, 55.06 %).

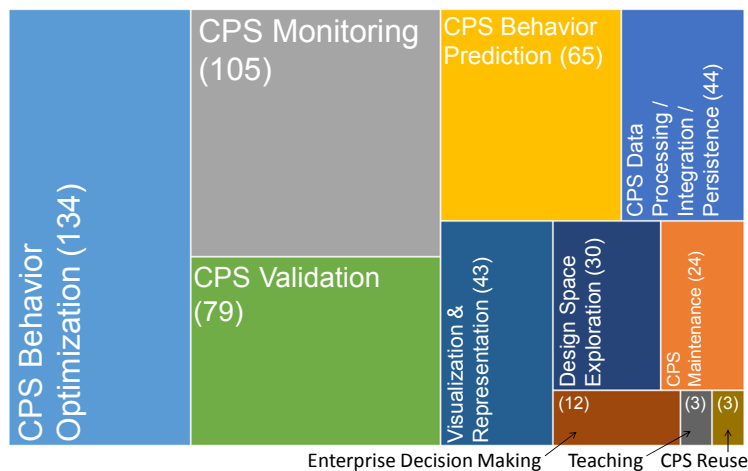

Figure 6: Purposes of Digital Twins

The four biggest clusters we identified are CPS Behavior Optimization (134, 37.64 %), CPS Monitoring (105, 29.49 %), CPS Validation (79, 22.19 %), and CPS Behavior Prediction (65, 18.26 %). With almost equal numbers CPS Data Processing, Integration, Persistence (44, 12.36 %), Visualization & Representation (43, 12.08 %). Of the other purposes, Design Space Exploration (30, 8.43 %) is mentioned more often than CPS Maintenance (24, 6.74 %), which is still mentioned twice as often as Enterprise Decision Making (12, 3.37 %). Almost not mentioned are Digital Twins for CPS Reuse (3, 0.84 %) and Teaching (3, 0.84 %).

These numbers show that most Digital Twins are either used for behavior prediction or optimization, which combined make a total of 199 (55.9 %) publications. Another huge application area seems to be CPS Monitoring and Visualization, which together make 148 (41.57 %) of the corpus. This shows that Digital Twins used today seem most likely to optimize, monitor, or visualize their physical counterpart.

4.5. RQ-2.1 - Digital Twin Counterparts

To uncover which kinds of counterparts Digital Twins are used with, we analyzed the publications in our corpus for this aspect. We found that mostly all publications made explicit what the counterpart of the presented Digital Twin concepts is. Out of the 356 (100 %) publications, a total of 350 (98.31 %) publications make the counterparts of their Digital Twins explicit. Overall, 31 (8.99 %) publications present research in which the Digital Twin supports more than one counterpart, for instance, when Digital Twins for the production system and the produced product [247] or a production process on an individual system [138] are considered. Overall, 384 counterparts are reported by the publications included in our survey, as illustrated in Figure 7.

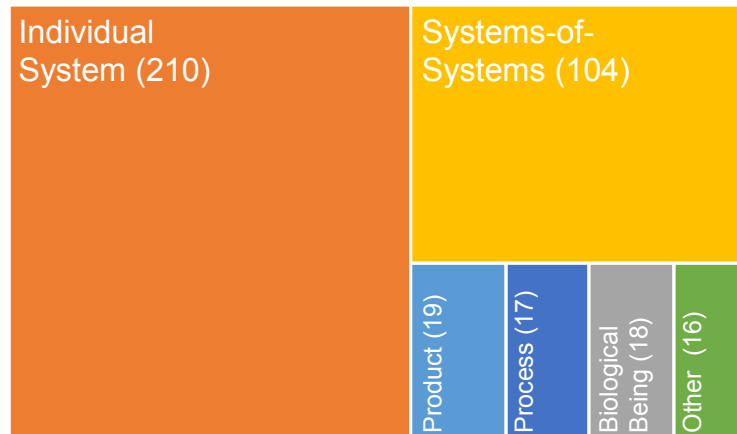

Figure 7: The predominant counterparts of Digital Twins are individual systems and systems of systems.

The predominant counterparts of Digital Twins are individual systems (210, 54.69 %) and systems of systems (104, 27.08 %), which make a total of 314 (81.77 %) of the Digital Twin counterparts identified in our corpus. Digital Twins for beings, processes, products, and other counterparts are significantly less common and make only a total of 70 (18.23 %) publications to the counterparts of Digital Twins.

Finding most Digital Twins relating to counterparts that are individual systems and systems-of-systems is not unexpected. However, the latter entails questions regarding the communication and (de)composition of Digital Twins that are further investigated in the context of **RQ-2.8**. Especially when individual systems can flexibly enter or leave system-of-systems structures, such as within smart manufacturing, automated convoys, or distributed Internet of Things systems, the interfaces of Digital Twins, their interactions, and means for flexible composition need to be understood.

The low number of publications contributing Digital Twins of products is unexpected as the smart product of lot-size 1 is one of the driving visions of Industry 4.0, and Industry 4.0 is one of the main disciplines driving research on Digital Twins. However, in line with the increasing number of publications on Digital Twins and the finding that the digital representation of assets still is one of the prime research topics, at least in modeling for Industry 4.0 [361] suggests that before the product can be twinned, first the assets and the processes relating to its production must be considered. Yet, there also is a small number of publications on Digital Twins relating to processes that are not tied to one or more systems directly.

The overwhelming focus on contributions to engineering Digital Twins for systems consequently indicates that research still is in a very early stage of understanding the systematic engineering of Digital Twins, means to reuse parts of Digital Twins for Digital Twins of different counterparts, and suggests that established reuse techniques from software engineering, such as encapsulation, type-based substitution, product lines are not as common for Digital Twins yet. We assume the latter is due to the different perspectives on Digital Twins as (design-time) models, (run-time) systems, or something in-between and the heterogeneous implementation techniques that are employed accordingly. Research on heterogeneous modeling [391] and software language engineering [384, 362] can contribute to closing the gaps between the different technological spaces [390] and applying established reuse techniques to Digital Twins systematically.

4.6. RQ-2.4 - Digital Twin Lifecycle

To understand how Digital Twins are applied to the different lifecycle phases of their counterparts, we classified the publications accordingly. As designed Digital Twins consider the ideal design of their physical entities, thus not taking into account minor derivations that may occur during the construction of the counterpart. As-manufactured Digital Twins do consider these derivations, while as-operated Digital Twins also include usage data which may inflict the physical counterpart's behavior or appearance. Figure 8 shows the distribution of described Digital Twins as a Venn diagram. In our corpus of 356 (100 %), all but 17 (4.77 %) publications made explicit which lifecycle the presented Digital Twin represents. A total of 60 (16.85 %) publications describe Digital Twins for more than one lifecycle, for instance, when Digital Twins for the design and manufacturing were combined [210]. Overall, 29 (8.15 %) publications also presented Digital Twins that were used across all lifecycle phases.

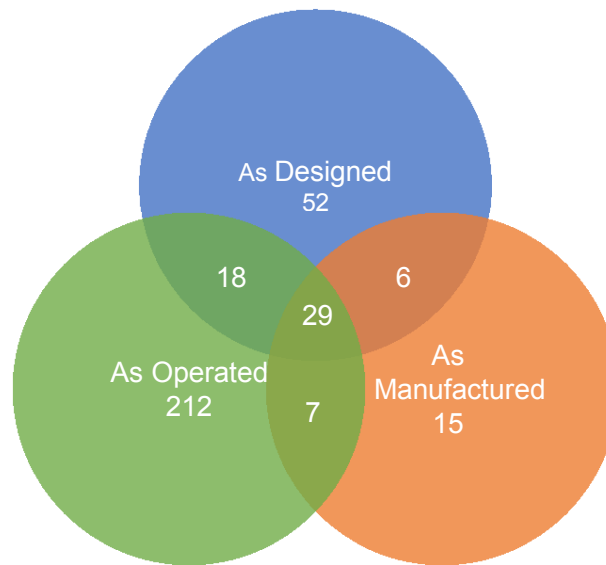

Figure 8: Lifecycle phases of Digital Twins

Most Digital Twins (266, 74.72 %) represented the operation lifecycle phase of the physical entity. This might indicate that Digital Twins are often employed for simulating the physical entity's behavior, e.g., if it is not built yet, or to test new application scenarios before they are realized. Also, when Digital Twins fulfill informative and representing requirements, they also integrate runtime sensor data to mirror the entity's state. It should also be pointed out that only 57 (16.01 %) publications consider the manufacturing of the physical counterpart, and only 15 (4.21 %) publications focus the manufacturing exclusively. Many of the Digital Twins described in the literature represent CPS with a long lifecycle, e.g., production machines. In such systems, sensors are often retrofitted, and Digital Twins are developed while the machine is already operating (brownfield Digital Twin development), to represent their counterparts as-operated, which explains the high number of publications reporting on Digital Twins for this lifecycle phase. However, representing the design of future systems by a Digital Twin can be beneficial to evaluate, e.g., different variants before the system is realized. Therefore an increase in design-time Digital Twins is expected in the future.

Another possible explanation for the derivation between frequency of as-designed and as-operated could be that the physical twin is designed once, but then multiple instances conforming to this design are produced. Thus, leading to only one as-designed Digital Twin but multiple as-operated Digital Twins where the as-operated Digital Twins represent different instances conforming to the same design. To enable co-evolution of physical objects and their Digital Twins, future research also should be conducted on the transformation from as-designed Digital Twins to as-manufactured Digital Twins and to as-operated Digital Twins.

Combinations of the different lifecycle phases are generally not researched thoroughly. Especially, transitions between Digital Twins (i) as-designed and as-manufactured; (ii) and as-manufactured and as-operated; and (iii) as-

operated back to as-designed yield promising potentials for a pervasive model-driven DevOps of Digital Twins that saves development time in the future.

4.7. RQ-2.6 - Digital Twin Optimization

With **RQ-2.6**, we investigate whether Digital Twins are used for optimization and whether the Digital Twins optimize their counterpart, themselves, or both. To this end, we classified Digital Twin optimizations mentioned in the publications of our corpus according to the classification schema presented in Section 3.4.

Overall, we found that out of 356 (100 %) publications, 193 (54.21 %) publications explicitly perform optimization, whereas 163 (45.79 %) publications do not mention or consider Digital Twin-based optimizations. Of the 193 publications making the Digital Twin optimization explicit, only 6 (1.68 %) publications present Digital Twins that only optimize the Digital Twin. Most publications present Digital Twins that optimize their counterpart (138, 38.76 %) or optimize both (49, 13.76 %).

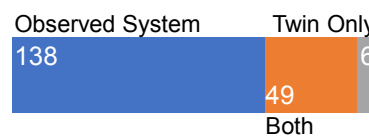

Figure 9: Regarding optimization, Digital Twins largely focus on the observed system.

These numbers show that most of the publications on Digital Twins of our corpus describe Digital Twins that optimize their twinned counterpart. Moreover, there is a clear trend to only optimize the virtual counterpart without adapting or optimizing the Digital Twin itself. As there is also a smaller proportion of papers that either describe the optimization of the Digital Twin alone or the Digital Twin and the observed system, it can be followed that further research on methods to optimize the Digital Twin parallel to the observed system might be required. In this context self-optimizing Digital Twins might benefit from models at runtime or self adaptive sources [6].

4.8. RQ-2.7 - Digital Twin Parts

With research question **RQ-2.7**, we aim to find out the essential components that are part of Digital Twins. We found that out of 356 (100 %) all but 33 (9.27 %) publications made explicit what they consider part of the reported Digital Twin. Of the publications making the parts explicit, a total of 144 (40.45 %) publications describe Digital Twins composed of more than one of the facets of parts, while none of the publications report on a Digital Twin that is composed of elements from all facets.

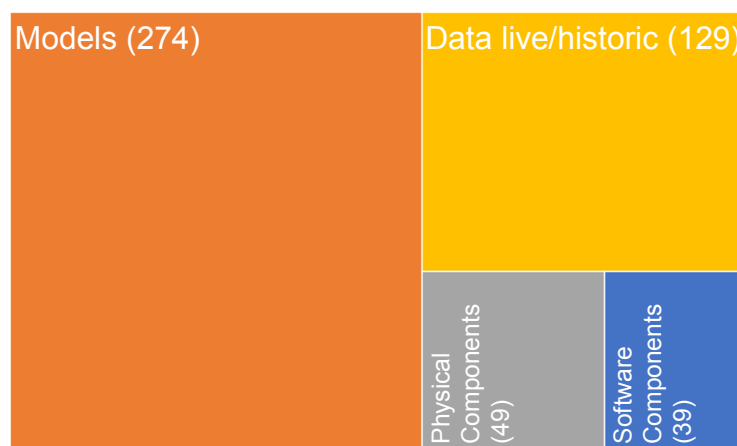

Figure 10: Distribution of Digital Twin constituents with models as the predominant factor.

Hardware components are also named as components of the Digital Twin. Since the Digital Twin is a digital object, the number of 49 (13.76 %) papers that also name hardware components seems surprisingly high. A possible

explanation are cyber-physical components whose functionality is realized by a combination of hardware and software components. This makes the boundary blurry and since software and hardware are delivered together, it is less recognizable for the user. In many applications, a combination of a Digital Twin together with a physical model is utilized to provide the user with haptic feedback. This is especially the case for Digital Twins used in training, e.g., for medical professionals [280].

Most publications (274, 76.97 %) mention models as parts of the Digital Twin. The terms “model” and “Digital Twin” are even used synonymously [2]. These models mainly describe the physical counterpart’s constraints (133, 37.36 %) and its appearance (94, 26.4 %). Only a few publications (18, 5.06 %) apply models for describing data structures and only 30 (8.43 %) publications describe Digital Twin behavior through models. The most frequently reported model types were simulations, physical models, and geometric models. This is consistent with the fact that many described Digital Twins come from the engineering field, where these types of models are highly prevalent [321].

Digital Twins often offer services, e.g., to evaluate system states [214] or to influence system behavior [215]. Thus, it is not surprising that (39, 10.95 %) publications mention software as a part of the Digital Twin.

Since Digital Twins often monitor CPSs at runtime, data is also mentioned as part of the Digital Twin frequently (129, 36.24 %) as well. To fulfill their representative purpose Digital Twins need information about the underlying system, which makes the data a reasonable part. Therefore, intelligent data processing and storage could become an important functionality of Digital Twins in the future, enabling them to remain up-to-date representation of the twinned system despite further growing data volumes.

4.9. RQ-3.1 - Implementation

Multiple publications not only elaborate on the conceptual foundations of Digital Twins but also provide a detailed explanation about used techniques for their implementation. Thus, **RQ-3.1** analyses different facets of realizations. Our goal is to identify key technologies or methodologies to implement Digital Twins. Overall, 191 publications contain information on implementation details. Thus, the following classification results refer to the total number of publications that actually contribute to the research question. As different technologies can be used in combination for realization, the following statistics are not disjoint.

Overall, 71 (37.17%) Digital Twin concepts are implemented using CAD or 3D models. Furthermore, 31 (16.23%) of the papers follow data-driven approaches, such as standardized data formats (e.g., JSON, XML) or complete database systems. General-purpose programming languages make a total of 65 (34.03%) publications. 59 (30.89%) approaches are realized via mathematical or physical models, and 38 (19.9%) use a model-based or model-driven approach. Finally, 42 (21.99%) papers consider simulations or similar analyses when implementing these twins. Figure 11 presents the corresponding distribution.

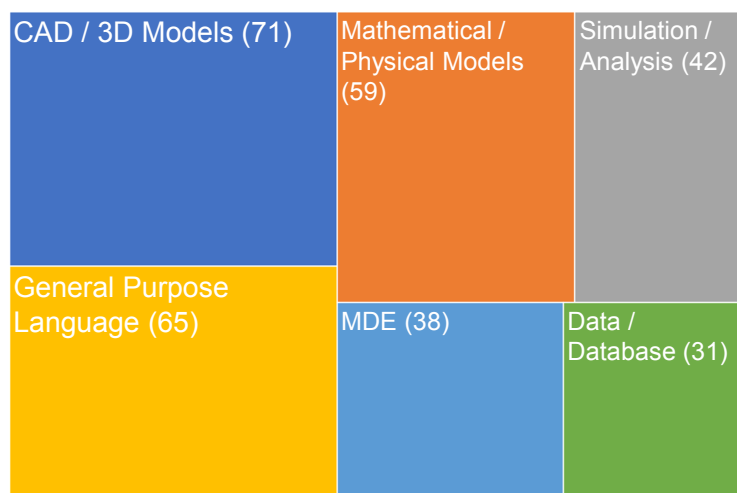

Figure 11: Distribution of implementation techniques for Digital Twins

In summary, most of the considered publications use 3D and mathematics-based models as well as general-purpose languages. Simulations, model-based, and data-driven approaches are also widely applied for implementing Digital Twins. Most publications also describe a composite approach of several technologies to realize Digital Twins. Furthermore, 8.71% of all publications describe the appliance of types or another kind of reuse. This relatively low percentage shows that many Digital Twins are still created in a purpose-driven way, without relying on a consistent foundation.

CAD or, more general, 3D models being the most prominent way of implementing Digital Twins is consistent with the findings of **RQ-3.2** and could indicate that a replica comprising the physical characteristics is often required. Furthermore, the use of general-purpose languages is significantly high. This suggests that for many aspects of a real-world entity or process, suitable tools do not yet exist, such that many features have to be implemented manually on an individual basis. Additionally, Digital Twins are often based on physical models, model-based techniques, simulations, and slightly less on data. Overall, this distribution seems to indicate that currently, these twins primarily rely on model-driven or analytic approaches rather than purely data-driven techniques.

4.10. **RQ-3.2** - Digital Twin Tooling

The purpose of **RQ-3.2** is to understand which kinds of software tools are applied to the engineering and operations of Digital Twins. To this effect, we classified the tools mentioned in the publications of our corpus according to the classification schema presented in the corresponding facet.

Overall, we found that only 186 (52.25 %) publications of 356 publications make the tools employed explicit. Various publications to Digital Twin architectures or infrastructures present concepts or methods that are unrelated to specific tools. Out of the 186 publications making the employed tools explicit, the most popular category of tools is simulation tools (70, 19.66 %), which includes the Maya Simulation Framework [25] Siemens PLC Sim Advanced [156], Simumatik 3D [148], Verosim [50], and more. The second most often category of tools focuses on computer-aided design and manufacturing (CAX) tools (53, 14.89 %), which includes Autodesk Revit [129], CATIA [33], Delima 3D Experience [263], Siemens NX [45], SOLIDWORKS [106], and similar tools.

Tools for process management (37, 10.39 %), communication (24, 6.74 %), data management (32, 8.99 %), visualization (35, 9.83 %), as well as the direct use of programming languages (34, 9.55 %), and model-driven development tools (33, 9.27 %), are less common than simulation and CAX. Moreover, there also is a large number of publication using various other software (36, 10.11 %), which includes website development for Digital Twin representation with Apache Kepler [248], interfacing specific robot APIs [141, 136], data modeling with Microsoft Excel [160], or specific programming environments [220]. Overall, the main categories of tools employed in the engineering and operations of Digital Twins are as illustrated in Figure 12.

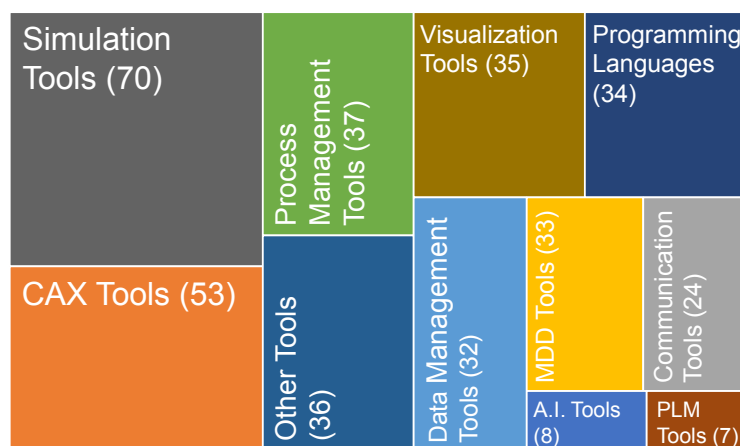

Figure 12: Simulation tools and CAX tools are used most often to develop Digital Twins.

The most prominent tools to engineer Digital Twins are simulation tools and CAX tools. This might indicate that some notions of Digital Twins indeed aim for a sufficiently precise replica of the twinned system that can be

subjected to experiments as a substitute for the twinned system itself. Moreover, this might entail that Digital Twins are predominantly researched in domains being used to describing systems for a physical-geometrical perspective (cf. **RQ-1.1**). As both simulation tools and CAX tools traditionally are employed to engineer systems, i.e., prior to the deployment of the system under development and its operations, this furthermore might suggest that there is a strong focus on Digital Twins used at design time of the twinned system. On the other hand, the widespread use of process management software, communication software, and data management software indicates that there also is extensive interest in observing and possibly optimizing the behavior of the twinned system at runtime.

The horizontal analysis on the use of tools relative to the domain (**RQ-1.1**), its purpose (**RQ-1.2**), and lifecycle (**RQ-2.4**) of the respective Digital Twins discusses this.

The number of process management tools and data management tools, ranging from traditional databases to data analysis tools might portend that Digital Twins also are about better understanding the twinned system and its operations in its context. Yet, in contrast to **RQ-2.1**, according to which twinning system-of-systems is important, the low number of communication tools employed to engineer and operate Digital Twins might suggest that from a Digital Twin perspective, Digital Twins of systems-of-systems are generally considered a single, monolithic system instead. This might be due to the lack of support for composing Digital Twins (cf. **RQ-2.7**).

With one interpretation of Digital Twins being that these are models of the twinned systems—which appears to be the predominant perspective on Digital Twins for the researchers employing simulation tools and CAX tools—the lack of applications of MDE tools is surprising. Again, this might be due to the large number of publications focusing on Digital Twins in manufacturing included in our corpus. Also, the number of papers leveraging general programming languages is relatively low. This might suggest that Digital Twins often are engineered and operated by reusing existing software, such as specific tools for simulation, data management, or visualization. If research on Digital Twins does not require new software, this might suggest that Digital Twins are not a new paradigm or kind of software per-se, but the combination of existing paradigms, methods, and tools for a new purpose. This also is in line with the observed lack of special software solely focusing on Digital Twin engineering or operations. The horizontal analysis of the use of tools (**RQ-3.2**) relative to the purpose (**RQ-1.2**) highlights this.

Finally, we found the lack of research employing artificial intelligence tools, including machine learning, knowledge representation, and planning, surprising.

4.11. RQ-3.3 - Digital Twin Development Processes

Analyzing whether Digital Twins are developed together with their counterpart or in an independent process in **RQ-3.3**, we identified that only 232 (65.17 %) make the engineering process of the Digital Twin explicit. Various publications address the usage of Digital Twins or broader concepts and do not address the engineering of Digital Twins or their counterparts.

The publications that made the engineering of Digital Twins explicit could be categorized into two categories, those which describe an engineering process intertwined with the counterpart and those that describe that Digital Twins are developed in a separate process. Furthermore, we identified whether the development of Digital Twins incorporated knowledge about the manufactured system or not if they are not developed together with their counterpart. Of the 232 (65.17 %) publications making the development process of Digital Twins explicit, a total of 7 (1.97 %) of 356 publications describe processes for Digital Twins both together with the development of the counterpart and also independent of it. Overall, 29 (8.15 %) publications report that the Digital Twin is developed together with the system, and 196 (55.06 %) that it is not. Of the latter, 14 (3.93 %) publications report that the development of Digital Twins is independent of any manufactured counterpart, whereas 26 (7.3 %) report that the development of a Digital Twin incorporates knowledge about the manufactured counterpart.

It is striking that Digital Twins are primarily developed in a separate development process, i.e., not in a joint engineering process with the actual system. This could be a result of historical developments or because the Digital Twin and its counterpart are primarily regarded as separate entities. Moreover, this might entail that Digital Twins are mostly researched in domains where there already exists strong engineering processes independent of Digital Twins. Integrating Digital Twins and the information they provide into a complex engineering process could present greater challenges and require a corresponding shift in mindset. After all, some articles describe the development of Digital Twins as anticipating the development of their counterparts. This suggests that information gained from Digital Twins is already flowing into the development of their counterparts, for example, for design space exploration. The next

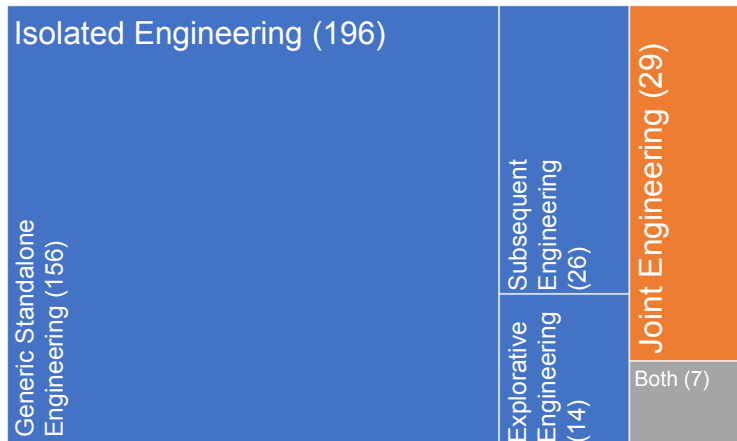

Figure 13: Distribution of the reported development process of Digital Twins

step here would probably be to develop Digital Twins and counterparts together in order to allow information to flow iteratively into the development process and thus to be able to react to changes in the development. However, it is also interesting that in some cases, the Digital Twin is developed after the actual counterpart. This could occur, for example, in cases where the counterpart is retrofitted with a Digital Twin that then interacts with the system at runtime, for example, to control or influence the system. However, we found that for the actual engineering of and with Digital Twins, there is a lack of research.

4.12. RQ-4.2 - Digital Twin Connections

We investigate how Digital Twins are connected to their counterpart. To this end, we classified Digital Twin connections mentioned in the publications of our corpus according to the classification schema presented in Section 3.4.

We found that 77 (21.63 %) explicitly connect the Digital Twin with their real-world counterpart. Out of these publications, 32 (8.99 %) explicitly name the technology they used for this connection. The technologies, together with their occurrences, are illustrated in Figure 14.

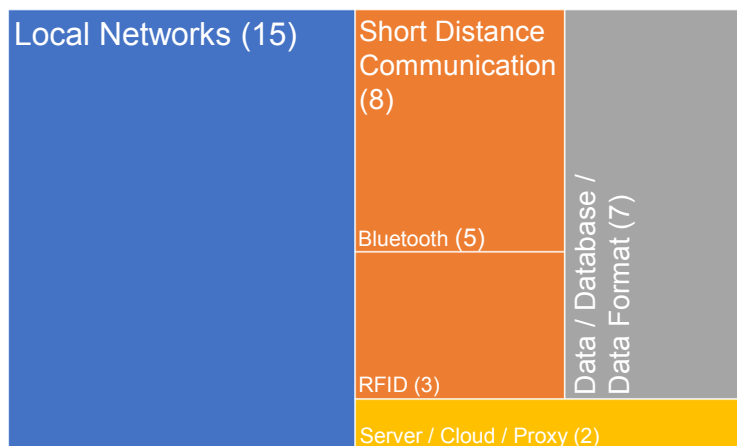

Figure 14: Digital Twin communication technologies

Most of the connected Digital Twins are connected with their counterparts via a local networks (15, 4.21 %), or short distance wireless communication (8, 2.25 %), such as Bluetooth (5, 1.4 %) and RFID (3, 0.84 %). Other publications mention that the Digital Twin is connected to the twinned system through data access via some database or

data format (7, 1.97 %) and via some cloud or server (2, 0.56 %). Furthermore, we classified the used communication scheme as also described in Section 3.4. The results are illustrated in Figure 15.

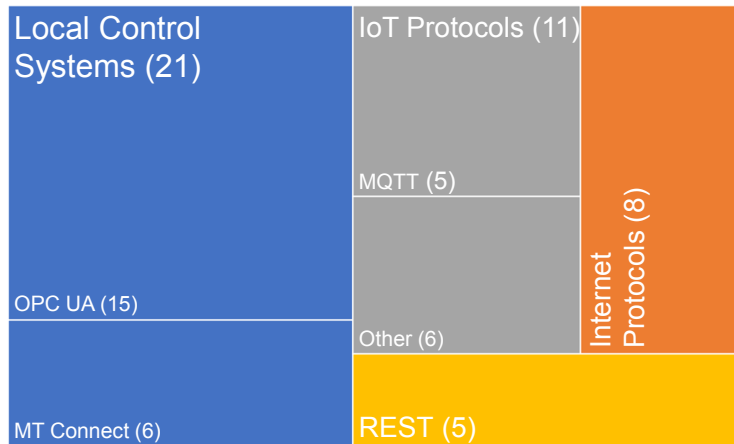

Figure 15: Digital Twin communication protocols

Most of the publications used protocols from industrial control system environments (21, 5.9 %). Of these publications, the majority (15, 4.21 %) use OPC UA and MTConnect (6, 1.68 %) to connect the Digital Twin with its real-world counterpart. Some publications mention MQTT (5, 1.4 %) and other IoT protocols (11, 3.09 %). Furthermore, internet protocols (8, 2.25 %) are used in some cases to connect the Digital Twin with its real-world counterpart.

From these numbers, it becomes clear that Internet technologies and protocols are the predominant means to connect Digital Twins with their counterpart. Moreover, it is easy to see that technologies and networks from IoT applications are also an important part of Digital Twin development and connection. The large number of industrial control system communication protocols and IoT protocol also meets our observation from **RQ-1** that Digital Twins are mostly used in the manufacturing domain in the context of industrial control systems. However, we can see from the relatively small number of publications that communication between the Digital Twin and its counterpart is currently not the main focus of research.

4.13. **RQ-5.1** - Decision Making Functions

The notion of Digital Twins often comes with the intention of optimizing systems or process optimization. Therefore, **RQ-5.1** investigates the possibility of decision making functions. The goal was to explore the most prominent decision methods used for Digital Twins. In general, it is noteworthy that 234 (65.73%) publications do not describe any explicit decision making functionality. Therefore, the following statistics apply to the remaining 122 publications.

As certain publications use several decision making functions, the categorization is not disjointed. Overall, 55 (45.08%) Digital Twin concepts use some kind of reasoning. Further investigation shows that only a few case-based reasoning is performed (four publications in total) compared to symbolic, stochastic, or other numerical reasoning methods (14 to 19 papers each). Other numerical reasoning represents the subset of reasoning methods that do not fit into the remaining three categories. Furthermore, 41 (33.61%) of the presented Digital Twins use machine learning techniques, and 31 (25.41%) rely on simulation. Data Mining techniques have the least impact, with only 12 (9.84%) publications reporting on this topic. Figure 16 presents the corresponding distribution.

In summary, only one-third of the publications describe decision making in combination with Digital Twins. Methods of reasoning, simulation, and machine learning seem to have made significant advances. Data Mining techniques are severely underrepresented. This is an interesting fact indicating that most decision making processes rely on analyzing near real-time data and do not perform exhaustive computations on historical data. This might be due to the lack of historical data and change in the future accordingly.

4.14. **RQ-5.2** - Digital Twin Inputs and Events

We aim to understand how Digital Twins gain information about their counterparts and the operating context and to which events and external inputs they react. We found that all but 129 (36.24 %) publications made explicit on

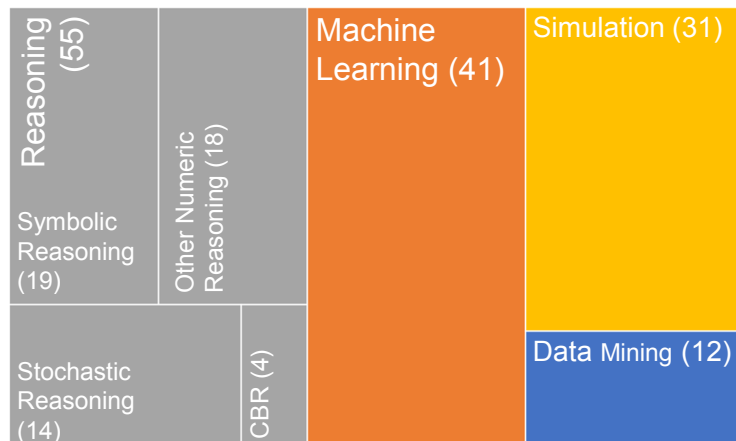

Figure 16: Distribution of decision making techniques

which input the presented Digital Twin relies. Of the publications making the Digital Twin's inputs explicit, a total of 45 (12.64 %) described Digital Twins processing multiple types of inputs. For example, several Digital Twins react to changes of machine data but also support reconfiguration [12], where a Digital Twin of a 3D printing machine automates experiments to detect parameters for achieving desired product attributes. For this purpose, the Digital Twin analyzes sensor data and also provided 3D specifications of the produced part. Most Digital Twins (177, 49.72



Figure 17: Inputs of Digital Twins

%) react to machine data as input. This aligns with the large number of Digital Twins from manufacturing and might simply stress that Digital Twins are often applied for automation in manufacturing. From these numbers, it is easy to follow that many Digital Twins tend to react to the data they receive or measure from their observed systems, from the system's users, or the systems environment. In addition, some Digital Twins appear to react to damage or fault events, which is consistent with our observation from **RQ-1.2** that Digital Twins can be used for maintenance purposes.

4.15. **RQ-5.3** - Digital Twin Output

We want to understand whether Digital Twins produce outputs and, if so, what kind of outputs they produce. To this end, we identified publications that reported that Digital Twins emit some output or affect the environment they are deployed in. We classified the kind of these outputs according to the classification schema presented in the corresponding facet.

Of the examined publications, 227 (63.76 %) made explicit that Digital Twins emit some kind of output. In cases where Digital Twins do not provide outputs, they could represent structural models instead of software that provides analyses. In some cases, Digital Twins performed analyses. However, it was not stated what happens with the analyses results or how these influence the environment or the counterpart.

Out of the 227 publications making outputs of Digital Twins explicit, a total of 66 (29.07 %) broadly stated that Digital Twins produce some kind of analyses result or emit some kind of data, but did not report any specifics on these outputs. This was, e.g., the case in publications that presented a high-level concept of Digital Twins that could fulfill varying purposes. Interestingly, 33 (14.54 %) papers reported that Digital Twins had as output some kind of effect on visualization by updating information shown in user interfaces or even updating producing whole 3D models. A total of 44 (19.38 %) publications reported that the output of Digital Twins represents the current state of

the counterpart, including information about material or energy consumption, defect information, or current system behavior. Instructions or modifications, i.e., what should change (76, 33.48 %), or predictions and estimations (42, 18.5 %) are also common outputs of Digital Twins.

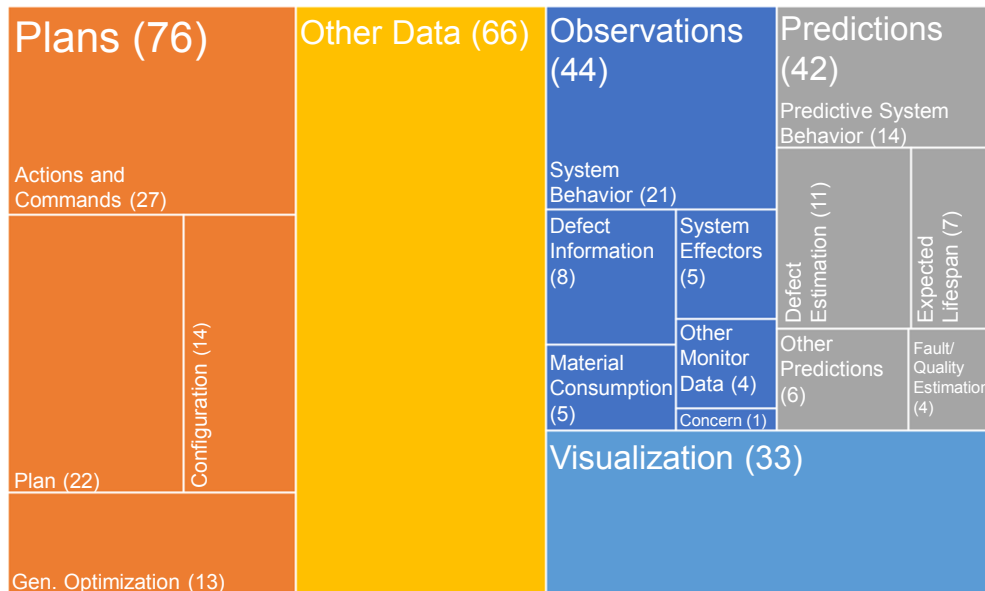

Figure 18: Distribution of the reported outputs of Digital Twins

Digital Twins can produce various outputs and consequently affect their environment, respectively counterpart in different ways. Most prominent are outputs that provide controlling data or instruction to the counterpart, ranging from changes of the parameterization to elaborated planning. These outputs are intuitive as they describe a strong interaction between Digital Twin and counterpart. The Digital Twin serves in particular as controller of the counterpart. With pure monitoring approaches, which also make up a substantial part of the examined publications, the question arises why Digital Twins are needed here. Monitoring approaches are probably intended to record the current state of the system as accurately as possible and make this information available to other systems. More sophisticated Digital Twins can not only examine the current state of the system but also make predictions, such as analyzing expected lifetime or predicting failure probabilities. Such Digital Twins could be used to monitor safety-critical systems in particular.

4.16. Further Insights

Not all research questions could be answered reliably by the publications included in our corpus. For these questions, this section presents our observations.

RQ-2.2 - Multiple Digital Twins. In our survey, we investigated whether the described Digital Twins are unique or if the described physical entity may have multiple Digital Twins. The majority of papers (251, 70.5 %) did not explicitly state how many Digital Twins are supported by their approach. Overall, only 63 (17.7 %) publications explicitly excluded the possibility of multiple Digital Twins while 42 (11.8 %) publications supported the idea of multiple Digital Twins.

RQ-2.3 - Lifetime. Throughout the mapping study, we also tracked whether the described Digital Twins were operated at designtime or at runtime of the physical counterpart. Most publications (282, 79.21 %) report on runtime Digital Twins and 97 (27.25 %) publications describe Digital Twins that are operated at design time of the physical twin.

RQ-2.5 - Interaction Facet. We also investigated whether current research considers the Digital Twin to interact with a twinned system. In our corpus, the majority of publications makes the interaction or the lack of it explicit (277, 77.81 %). Among the publications making interaction explicit, the majority (164, 46.07 %) supports interaction between the Digital Twin and its counterpart. The other (113, 31.74 %) publications do not support such interaction. This might be due to the different times a Digital Twin is employed in the lifecycle of its observed system and is discussed in the horizontal analysis.

RQ-3.4 - Quality Assurance. We also found that only a small number publications (51, 14.32 %) of our corpus consider quality assurance for Digital Twins at all. Where quality assurance was considered, testing (24, 6.74 %) was more prominent than simulation (21, 5.9 %). Also, the number of publications considering the online verification of Digital Twins with their counterparts is vanishingly low (7, 1.97 %). This implies a need for further research regarding the quality assurance of Digital Twins (1) at design-time of the Digital Twin; (2) during design-time of the twinned system; and (3) during runtime of both systems. Especially, the fidelity of Digital Twins, i.e., the verification that these can properly represent the twinned system at needs further investigation.

RQ-3.5 - Requirements. In addition to quality assurance measures, we also investigated whether own requirements for Digital Twins and their development are considered in the publications of our corpus. As a result, we found that only 38 (10.67 %) publications discuss own requirements for Digital Twins. Of these publications, most prominently the necessity of real-time capability was mentioned (7, 1.97 %) closely followed by the requirement that the behavior of the Digital Twin must match the behavior of its real-world counterpart (7, 1.97 %). Finally, it was mentioned that Digital Twins have to be reusable in only (2, 0.56 %) publications, which is almost negligible. The remaining publications that mentioned Digital Twin requirements, were either the only source in our corpus mentioning this requirement, or discussed the necessity of Digital Twin requirements without going into the details.

Since apparently only a few authors have investigated the specific requirements of Digital Twins, it is reasonable to conclude that Digital Twin specific requirements are currently not focused in research. However, the above-mentioned Digital Twin specific requirements obviously focus on important aspects of Digital Twin development such as real-time capability or the Digital Twins behavioral relationship to its physical counterparts. Thus, we think that further research on the requirements for Digital Twins and their implementation may be necessary in future works on Digital Twins.

RQ-4.1 - Digital Twin Host. We were furthermore interested which systems host Digital Twins. The investigation showed a wide variety of concept and technologies used, ranging from the the Digital Twin living on the same device as its counter part to the Digital Twin being deployed in a cloud. Only few publications (3) report that the Digital Twin lives on the edge of its counterpart. Of the publications that reported that the Digital Twin is deployed further away from its counterpart, 81 reported that the Digital Twin its deployed in the cloud, 8 reported that the Digital Twin lives on a specifically named platform, while 11 contributions do not further clarify on what kind of external system the Digital Twin is deployed. Also, 5 publications report on deploying the Digital Twin on the edge of its counterpart. For another 4 publications, the Digital Twin is managed in a database, and for 2 contributions it is part of a virtual reality. In summary, the different implementations show the diverse perception of Digital Twins, but it is clear that network-based systems and management in the cloud are strong pioneers here.

RQ-6.1 - Digital Twin Evaluation Maturity Facet. We found that the majority of publications in our corpus feature some form of evaluation (271, 76.12 %). Overall, proof-of-concept (TRL 1-3) evaluations are significantly prevalent (181, 50.84 %). Evaluations featuring technologies employed in a laboratory or relevant environment (TRL 4-6) are reported less often (77, 21.63 %) and evaluations featuring system prototypes in operation environments (TRL 7-9) are very rare (13, 3.65 %). As Digital Twin research often aims at the application domains of manufacturing, energy, or construction, the low number of evaluations featuring systems in their operation environments is comprehensible: evaluating a research product in a real factory, power plant, or construction site is challenging and costly. Yet, with Digital Twins aiming to improve productivity, this validation in the field ultimately is necessary to promote Digital Twin research into industrial practice.

5. Orthogonal Analysis

The orthogonal analysis investigates the potential correlations between related dimensions of our classification framework. To this end, we juxtapose several dimensions and further group their data to generate interesting findings. In addition, we investigated other pairs of dimensions which are not explicitly presented in this paper. Based on these investigations, we present the six most interesting analyses. Further analyses can be performed based on the replication package our replication package⁶.

5.1. Digital Twin Purpose (RQ-1.2) vs. Lifetime (RQ-2.3)

Our investigation of **RQ-2.3** revealed that most Digital Twins operate at runtime of the twinned system rather than at its design-time. However, since we suspect a correlation between the purpose of Digital Twins and their lifetime, we examine this relationship in more detail. Since for both, Digital Twin lifetime and Digital Twin purpose, the identified categories are non-disjoint and a publication can therefore be assigned more than once, the number of combinations considered here is larger than the number of publications. That is, the 356 publications of our corpus contribute to 638 combinations of Digital Twin purpose and Digital Twin lifetime, as shown in Figure 19.

In the vertical analysis, we identified that Digital Twins are more often employed at runtime than at design-time of the twinned system Section 4.4. Following this trend, CPS Behavior Optimization (145 observations, (79.31 %)) and Monitoring (116 observations) are predominantly performed at runtime. On the other hand, validation is more often performed at design-time (92 observations, (66.3 %)) than the overall trend suggests. Only design-space exploration is more often mentioned in publications presenting Digital Twin at design-time of the twinned system than at runtime, which also meets the intuition that design-space exploration is performed at the design-time of a system.

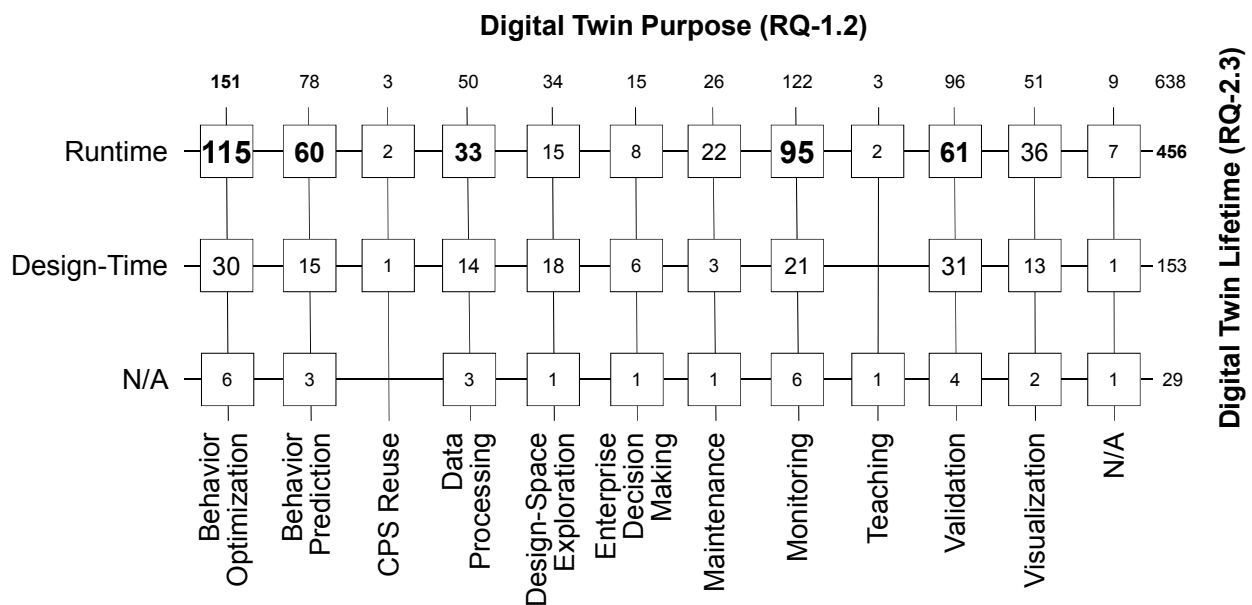

Figure 19: Digital Twin purposes relative to observed lifetime phases

Interestingly, a high percentage of contributions to design-space exploration of Digital Twins refers to runtime data for the design-space exploration. As the idea of using runtime data of system under development seems counter-intuitive, we looked at the publications again to get a better understanding of these cases. By this, it became clear that most of these publications consider multiple purposes at different times of the Digital Twins lifecycle [152, 179, 351], use real time data from similar products [129, 190], or perform experiments to get the required real time information at design-time [67].

⁶<https://zenodo.org/record/6560195>

5.2. Digital Twin Purpose (RQ-1.2) vs. Lifecycle Phase (RQ-2.4)

While the vertical investigation of **RQ-2.4** finds that most Digital Twins aim to describe, monitor, or control the twinned system as-operated, this section relates the lifecycle phases of the twinned system that are observed or represented by Digital Twins to the Digital Twins purposes uncovered through **RQ-1.2**. Through this analyses we aim to better understand for which purposes Digital Twins are used with respect to the observed systems lifecycles and whether there are gaps on this. While some purposes might appear to be obviously related to certain lifecycle phases, such as that Digital Twins with the purpose of supporting system maintenance might more often be used with the systems as-operated, other purposes, such as behavior prediction or enterprise decision making are equally suited for Digital Twins twinning systems as-designed, as-manufactured, or as-operated. Understanding the relation between Digital Twin purpose and the twinned lifecycle phases of the observed system sheds light the use of Digital Twins and can guide further research.

Overall, the 356 publications of our corpus contribute research to 799 combinations of purposes and lifecycle phases. This is due to many publications considering multiple purposes for Digital Twins presented in their research. For instance, the Digital Twin presented in [8] aims to ease CPS data processing, monitoring, behavior prediction, and behavior optimization. Hence, this publication contributed four entries to this orthogonal analysis as presented in Figure 20.

Generally, we have found five times as many publications that focus on Digital Twins of systems as-operated than on the systems as-manufactured and two times as many that focus on as-designed than on as-manufactured. As illustrated in Figure 20, these are not distributed evenly over the different purposes. For instance, research on Digital Twins for CPS behavior optimization and CPS monitoring often focuses on Digital Twins twinning the observed system as-operated. To this end, Digital Twins often are considered software systems that collect data from the observed system and process that to represent it to human operators [4, 235, 236] or control the system directly [28, 115, 353]. In contrast, research on Digital Twins for CPS behavior prediction instead focuses on Digital Twins as manufactured [22, 111, 217]. And research on Digital Twins for CPS validation and CPS design-space exploration focuses on the systems as-designed [278, 94, 73].

Considering the lifecycle phases globally, it is apparent that behavior optimization is the most important topic for Digital Twins relating to any of the three phases.

Overall, research on Digital Twins that aims to improve the behavior optimization, behavior prediction, data processing, monitoring, or validation for Digital Twins that twin their observed system as-operated makes up the five most important combinations of Digital Twin purposes and lifecycle phases and contribute a total of 351 (43.93 %) to the 799 combinations of purposes and lifecycle phases (highlighted with bold numbers in Figure 20).

As discussed in the vertical analysis, Digital Twins twinning systems as-operated make up the large majority of approach in current Digital Twin research. This might indicate that Digital Twins are closely related to real-world data processing or the consideration of real-world effects, such as hardly foreseeable environmental conditions, system uses, or highly detailed wear-and-tear. However, this focus of Digital Twin research vanishes where Digital Twins are used for validation or design-space exploration, where Digital Twins of the observed system as-designed are more prominent. As design-space exploration and validation typically are activities performed during systems development, this might indicate a gap between Digital Twins used during systems design for these purposes and the Digital Twins used during real operations of the developed systems. We suggest investigating this gap as well as means to reduce it, e.g., the derivation of a Digital Twin for a system as-operated from a Digital Twin of the same system as-designed or as-manufactured.

5.3. Digital Twin Lifetime (RQ-2.3) vs. Parts (RQ-2.7)

As Digital Twins exist at different times (**RQ-2.3**) and may also consist of various parts (**RQ-2.7**), this section examines the correlation of both corresponding research questions. We investigate which constituents are prominent as their diversity is very likely concerning the different purposes of a design-time and runtime twin (cf. Section 5.2). While some parts can obviously be related to a certain lifecycle phase, such as the use of models during design-time, there are also constituents that may exist to unexpected phases (e.g., historical data during design-time). Understanding the relationship between the lifecycle of Digital Twins and their parts assists their further engineering.

Overall, 591 combinations have emerged from comparing the lifecycle and constituents of Digital Twins. While 428 (72.42%) of the combinations describe a twin at runtime, some interesting correlations still appear.

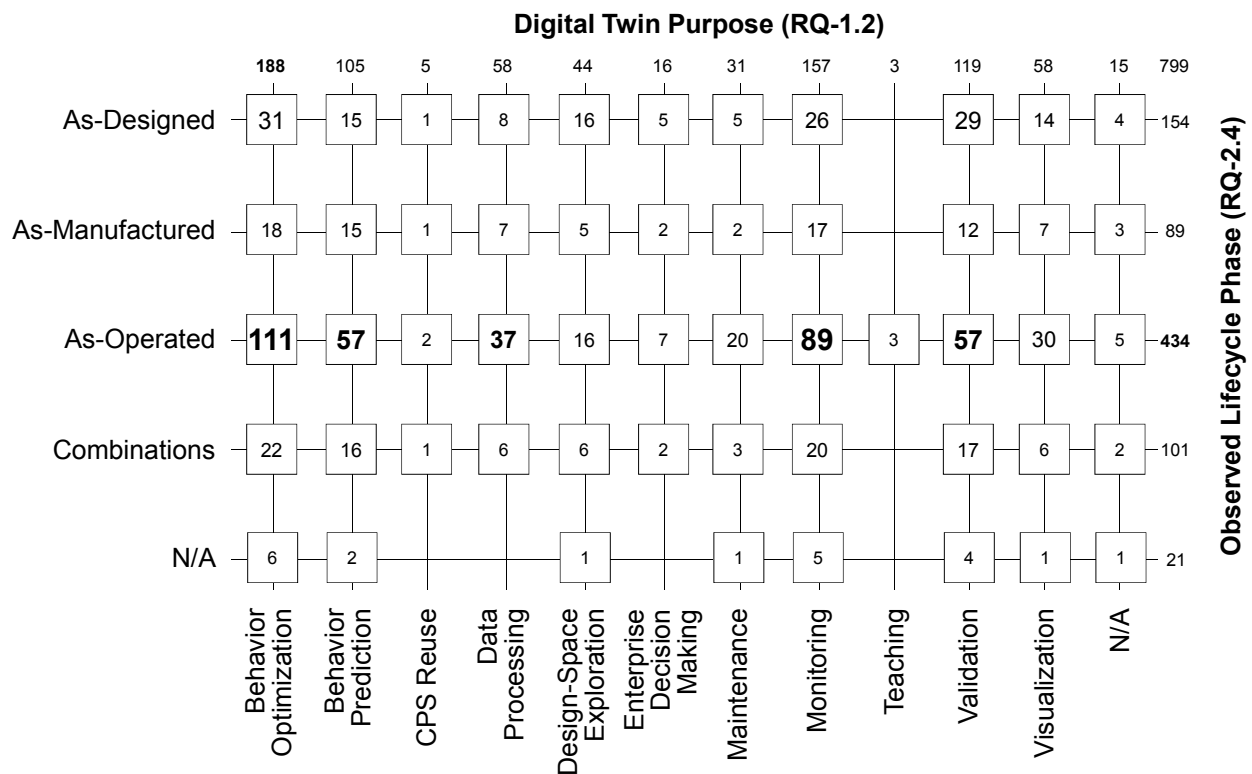

Figure 20: Digital Twin purposes relative to observed lifecycle phases

Generally, Digital Twins that exist during the runtime of the observed entity tend to use relatively more hardware components as during design-time. The same observation can be made for historical and live data. Additionally, this leads to the intriguing question of how a Digital Twin can access such data in the first place since it exists before the system under investigation is put into operation. In general, models are often part of Digital Twins as they are involved in 312 (52.79%) realizations.

The frequent use of hardware components and data at runtime of the system is intuitive since they are effectively available at this lifecycle phase. Generally, the question arises to what extent hardware can be part of a purely digital system at all; however, this result can be related to the authors' interpretation of Digital Twin constituents. For instance, sensors that are dedicated to produce input for a twin's computation could be considered part of a Digital Twin. Thus, some authors seem to include the required hardware infrastructure, while others clearly distinguish between hardware and software.

The use of hardware, as well as historical and live data at design-time, can have different origins. The Digital Twin could use hardware prototypes and simulations that produce input data. Furthermore, a twin might be subject to a bootstrapping process, in which a system is developed from previous versions of a similar system, enabling access to legacy components and recorded data traces.

The overall outstanding use of models as part of Digital Twins indicates a growing application of model-driven techniques. Beyond the extensive benefit of models at design-time, however, their predominant use at runtime of a system is also significant. One explanation might be that models that were already created during development are also stored in the Digital Twin (e.g., for documentation purposes). Furthermore, this finding might indicate a growing relevance for models at runtime, applying changeable models in the behavior of the overall system.

5.4. Digital Twin Decision Making (RQ-5.1) vs. Lifetime (RQ-2.3)

This subsection relates the Digital Twin's lifetime with its decision-making capabilities. Figure 22 shows a mapping between the possible lifetimes of a Digital Twin that can either be design-time or runtime and different techniques

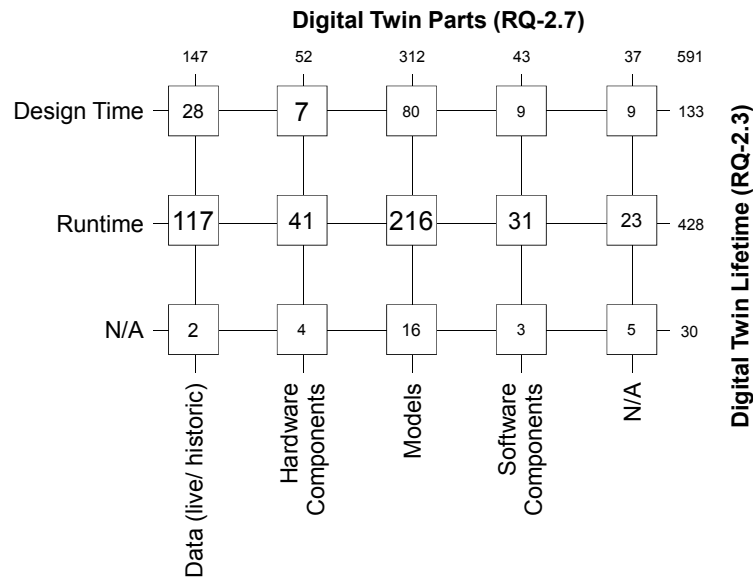

Figure 21: Digital Twin lifetime relative to observed parts

for decision-making that were reported as Digital Twin capabilities. The Digital Twin's ability to respond to its context seems to be related to its lifetime. Of the publication on Digital Twins investigated in our study, 93 (26.12 %) are able report decision-making capabilities. Of these, 30 (8.43 %) publications reported on decision making at design time while 126 (35.39 %) publications applied decision making at runtime. As these numbers indicate, there must be an overlap between Digital Twins that apply decision making at design-time and those that apply decision making at runtime. More specifically, all Digital Twins that apply decision making at design time also apply decision making at runtime.

At design-time, simulation is especially applied for decision making (11, 36.67 %). At runtime, 40 (31.75 %) Digital Twins applied machine learning, 26 (20.63 %) relied on simulations, and 15 (11.9 %) Digital Twins used symbolic reasoning.

While it is intuitive that Digital Twins perform adaptations autonomously at runtime, there seems to be a research gap for Digital Twins that act on their own at design-time. However, Digital Twins that evaluate different designs at design-time and create an optimal configuration of the designed product could decrease development times in the future.

5.5. Digital Twin Connection Types (RQ-4.2) vs. Lifetime (RQ-2.3)

The goal of this section is to understand which connection techniques can be applied at which lifetime of the twinned system. For example, if communication requires spatial proximity between the communicating entities. In total, 14 (3.93 %) publications reported a Digital Twin that was connected and applied at design time, respectively 114 (32.02 %) publications reported a Digital Twin that was connected and applied at runtime of the counterpart.

This discrepancy is quite intuitive since many Digital Twins encapsulated sensor data (Section 4.8) as part of the Digital Twin and thus require a connection to the physical counterpart to acquire this data. These runtime Digital Twins were often connected via local area networks (28, 24.56 %), or support OPC UA (21, 18.42 %) or internet protocols (15, 13.16 %).

Integrating sensor data or historical data into Digital Twins that are employed at design time, can support learning from usage information and adapting future versions of the physical twin. Of the design time Digital Twins (6, 42.86 %) were connected via OPC UA, thus integrated runtime data of operating physical things.

Considering Figure 23, the majority of design time Digital Twins do not mention their connection, yet. Thus, further research in integrating data from operating twins or the envisioned operation context is still relevant.

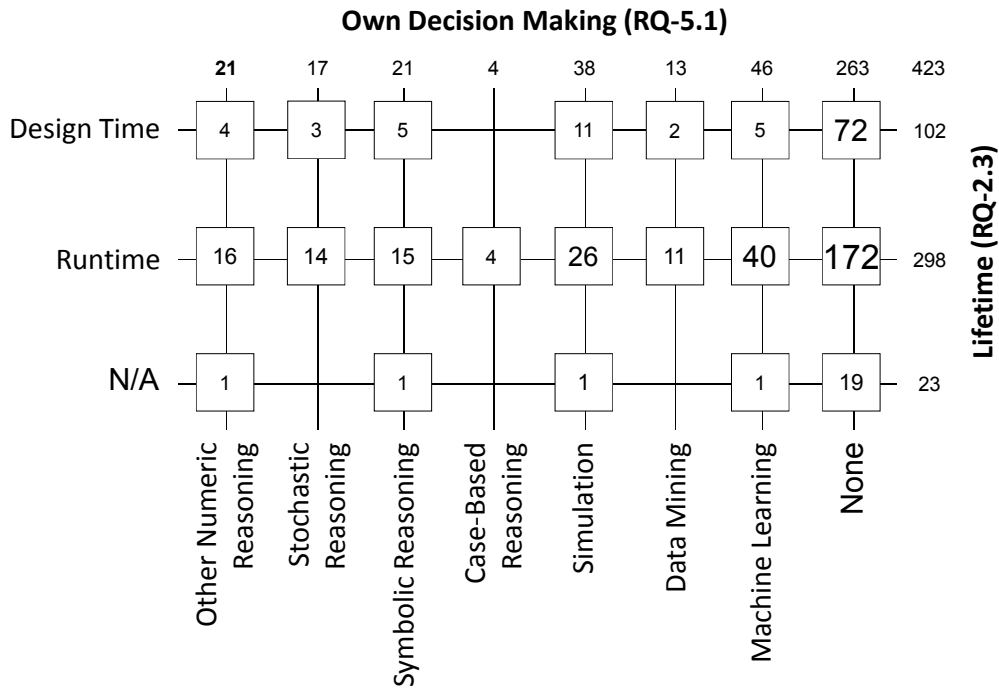

Figure 22: Relations between lifetime and decision making

5.6. Digital Twin Implementation Techniques (RQ-3.1) vs. Lifecycle Phase (RQ-2.4)

The orthogonal analysis relating implementation techniques to the lifecycle phases the Digital Twin addresses (cf. Figure 24) aims to uncover which techniques are best suited for the twinning a system as-designed, as-manufactured, or as-operated. Consequently, it also might identify gaps in research in form of technologies not applied to specific lifecycle phases.

Overall, the 356 publications of our corpus contribute research to a total of 678 combinations of implementation techniques and lifecycle phases. This occurs as many publications combine multiple implementation techniques and consider several purposes for Digital Twins presented in their research.

Generally, research on Digital Twins as-operated produced two times as many contributions than research on Digital Twins as-designed and and four times as many on Digital Twins as-manufactured. The high number of publications not making their implementation explicit (225, 33.18 %) suggests that much research on Digital Twins actually focuses on conceptual research that cannot be translated into Digital Twins without further information.

Hence, out of the five most popular facet combinations, two belong to the “N/A” column, i.e., where the technique of implementation is unspecified. This suggests that there are many publications reporting conceptual contributions to Digital Twin research. In our corpus, these most often are high-level reference models on the similar conceptual abstraction than RAMI 4.0 [383] that suggest how to organize architectures of Digital Twins without implementation [12, 97, 107]. The other three most popular facet combinations belong to research on Digital Twins as-operated while using CAD models, General-Purpose Programming Language (GPL) code, or mathematical models, which suggests that purely data-driven approaches, MDE models and simulation models are less relevant implementation techniques for Digital Twins.

For Digital Twins as-designed, CAD and 3D models as well as mathematical models are the primary implementation techniques, which make up 55 (52.38 %) of the contributions to corresponding Digital Twin research. While for Digital Twins as-manufactured, the applied implementation techniques are distributed almost evenly, the overall numbers of contributions to such Digital Twins is too small to generalize.

Overall, the data suggests that CAD and 3D models are overproportional important for developing Digital Twins as-designed, where they account for 36 (25.17 %) of the overall as-designed contributions. In contrast, for Digital Twins as-operated, they only make up 45 (12.89 %) of the overall as-operated contributions. Similar observations

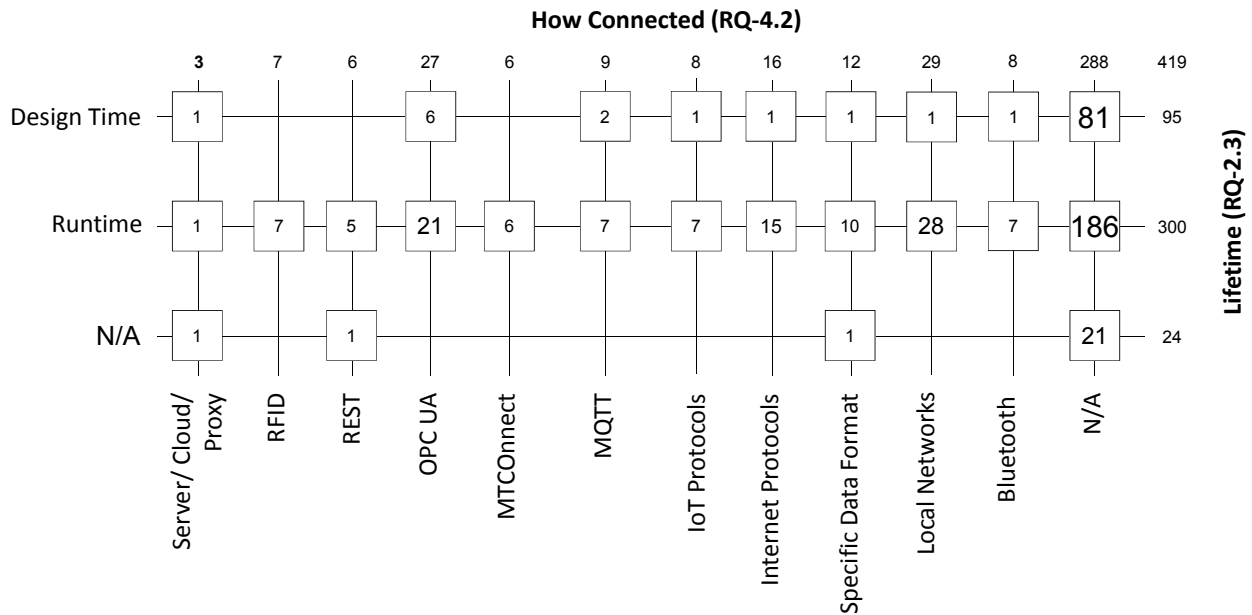

Figure 23: Relations between Digital Twin lifetime and their connection to the twinned system

hold for simulation implementations, which seem to be more important for Digital Twins as-designed (16, 11.19 %) than for Digital Twins as-operated (31, 8.88 %).

The different prominence of implementation techniques for Digital Twin research focusing on different lifecycle phases of the twinned system might suggest a technological gap between Digital Twins used to twin systems as-designed and Digital Twins used to twin systems as-operated. This also could explain the low number of Digital Twin research addressing more than one lifecycle phase of the twinned system.

6. Engineering Dimensions of Digital Twins

While reading the included publications, we noted and synthesized a collection of concerns that need to be considered when engineering and operating different digital twins. We have clustered and arranged these in the feature models presented in the following. Note that each intermediate feature refers to the research question its subfeatures where extracted from. Overall, we have identified four dimensions of digital twin engineering and operations:

1. The *requirements dimension* comprises concerns that define the capabilities of the Digital Twin under development. Design choices within this dimension include identifying the Digital Twin's counterpart, defining whether there can be one or multiple Digital Twins of the same system, and fixing the phase of the twinned system that the Digital Twin shall represent. Decisions made along this dimension govern *what* the Digital Twin under development will be capable of.
2. The *realization dimension* comprises concerns about implementation techniques, tools, and methods applied to engineering Digital Twins. Design choices within this dimension include selecting modeling and programming languages, a development process, and suitable quality assurance techniques. Decisions made along this dimension essentially govern *how* the Digital Twin will be developed.
3. The *deployment dimension* is about bringing the Digital Twin to life and includes concerns about hosting and connecting the Digital Twin. Design choices include deploying the Digital Twin locally, in the cloud, or in-between, installing it on a simulator or in a virtual environment, and selecting appropriate means to connect it to its counterpart(s). This dimension governs *where* the Digital Twin will exist.

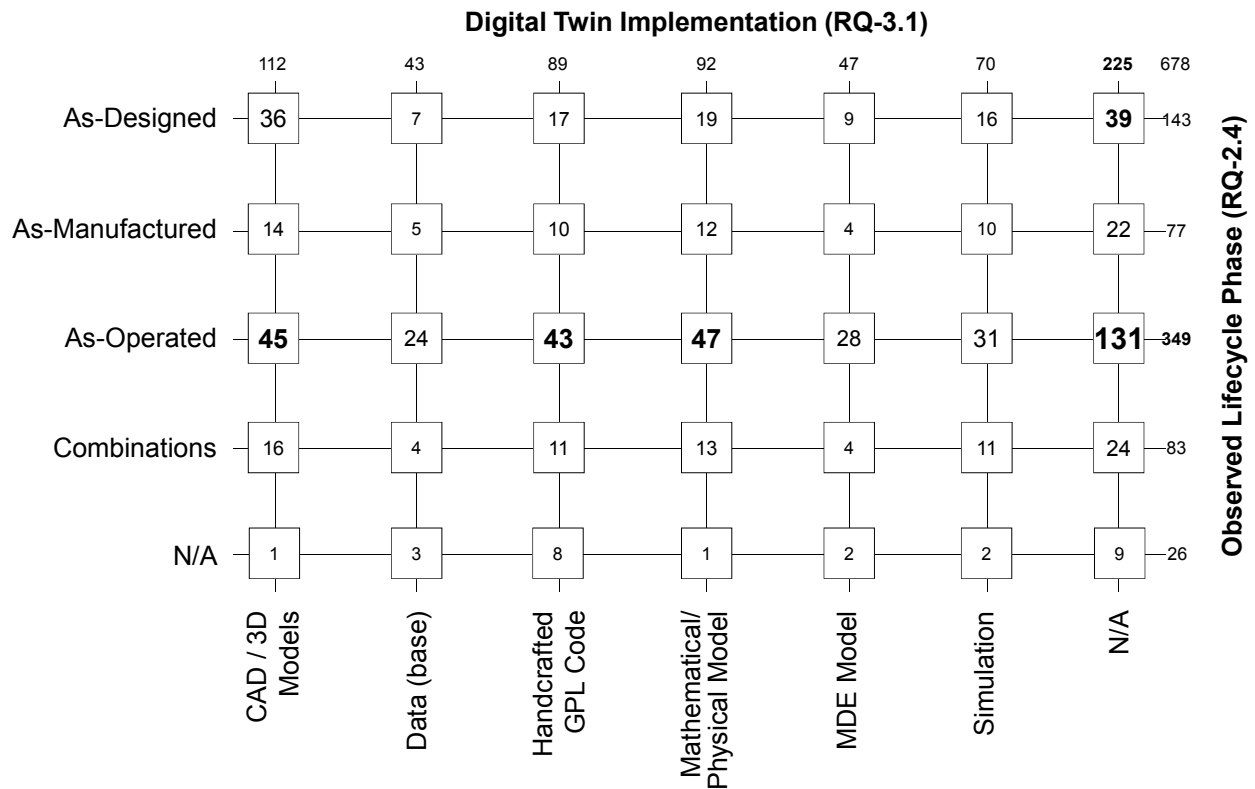

Figure 24: Digital Twin implementation techniques relative to addressed lifecycle phases

- The *operations dimension* is about the Digital Twins runtime behavior. It includes concerns about stimuli the Digital Twin reacts to, interaction with other systems (such as enterprise information systems), and decision making techniques influencing its behavior. Hence, this dimension governs *what* the Digital Twin will do.

Developing a Digital Twin involves making choices for each characteristic along these dimensions. To support this, the feature models presented in the following make these dimensions and their concerns to Digital Twins explicit and guide Digital Twin engineers and users. Therefore, we considered all research questions that apply to these dimensions and have categorized them accordingly.

6.1. Requirements Dimension

The requirements dimension covers the conceptual foundation for Digital Twins. These cover the basic constituents and characteristics a Digital Twin must or can have to fulfill its purpose. Figure 25 provides a general overview of conceptual features: To realize a Digital Twin, there must be some kind of real-world entity in the first place that acts as its counterpart. However, this requirement does not contradict the actual usage phase of the observed entity. Thus, a Digital Twin may exist before its physical counterpart. Overall, we investigated three types of counterparts, the first one of which is a living being, considering an individual. Furthermore, the physical twin can be a dedicated system, for instance, a production machine in a factory. Finally, a Digital Twin can observe a composed system (i.e., a system of systems), where multiple sub-systems are included. This situation focuses more on an overall goal than on supervising individual components. Digital Twins for systems of systems often prove to be very mature.

The second requirement on Digital Twins deals with the question of whether a real-world entity may feature multiple twins. This topic is highly controversial, and there are different approaches. On the one hand, some argue that by the nature of Digital Twins, there can only be one twin for a physical counterpart, managing all tasks for fulfilling its purpose. On the other hand, a Digital Twin might have a specialized view on a distinct part of a system,

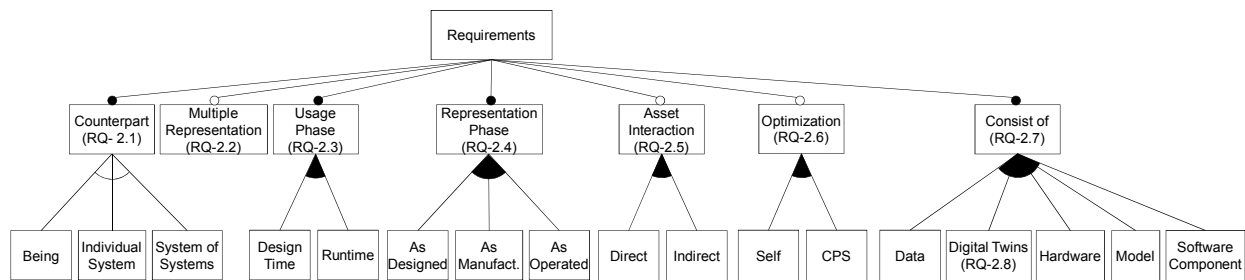

Figure 25: Requirement dimensions of Digital Twins in terms of a feature model

thus allowing the coexistence of multiple Digital Twins for a single observed entity. While there are pros and cons to both views, twin developers should consider this issue from the start to avoid potential conflicts later on.

A Digital Twin may exist at different stages in the lifecycle of a system. During design time, it supports the development and during runtime the system's operation. There may exist twins that cover both. Furthermore, independent of its stage of existence, a Digital Twin can also represent different lifetime phases of the observed entity. Therefore, Digital Twins can represent an entity as designed, as manufactured, or as operated. Again, multiple selections are possible if the twins should cover more than one specific phase.

As there are different concepts on Digital Twins, the approaches also differentiate regarding the interaction with their real-world counterparts. Some propose that the nature of a Digital Twin always includes direct interaction between the twin and its asset, while others are content with a pure indirect approach. As the kind of interaction (or if any exists at all) strongly depends on the Digital Twin's purpose, different realizations, including a combination of both attempts, are quite possible here.

Furthermore, a Digital Twin can be part of an optimization process. Our study revealed two main possibilities. First, a twin could optimize itself, e.g., to improve its own analyses or give a more accurate representation of the counterpart's state. Second, the observed system can be optimized directly by automatically taking measures for specific situations. Generally, also a combination of both approaches or no optimization at all might be feasible, depending on the goal.

Finally, a Digital Twin must consist of some conceptual constituents. There are multiple different approaches, including hardware and software components, data, models, or again other Digital Twins. Often, a combined effort of different approaches is used. While some findings, such as the reliance on some hardware or software, are expected, there are also further interesting building blocks. For instance, the use of models indicates an increasing notion towards model-driven approaches (cf. Section 4.9). Another interesting aspect is the involvement of other Digital Twins. The possibility of composing different twins to cover distinct sub-tasks comes with new possibilities but also challenges and shows growing sophistication in the development of Digital Twins.

6.2. Realization Dimension

From an engineering perspective, it is important to know how Digital Twins are implemented, which tools are used for their implementation, and which process is used for the Digital Twin development. For the realization of Digital Twins, we propose a feature model as described in Figure 26. We describe the properties of these engineering aspects in the following.

Every Digital Twin has an implementation, which defines how it achieves its purposes. In general, we identified that Digital Twins describe a counterpart's geometry, (software) systems, behavior, and general information about the counterpart. To describe a Digital Twin's geometry, the CAD/3D Model feature provides a modeling implementation for geometry description and design. Moreover, the data feature describes an implementation to handle information about the Digital Twins counterpart. We also noted that behavior descriptions are often implemented as mathematical (including stochastic models) or physical, as well as simulations. Finally, we identified that the implementation of concrete systems is often also realized as handcrafted GPL code and MDE models.

In addition to the implementation, we also identified several tools that may be used for the implementation. For this, we identified A.I. tools that use the information from the counterpart's data to make predictions and provide

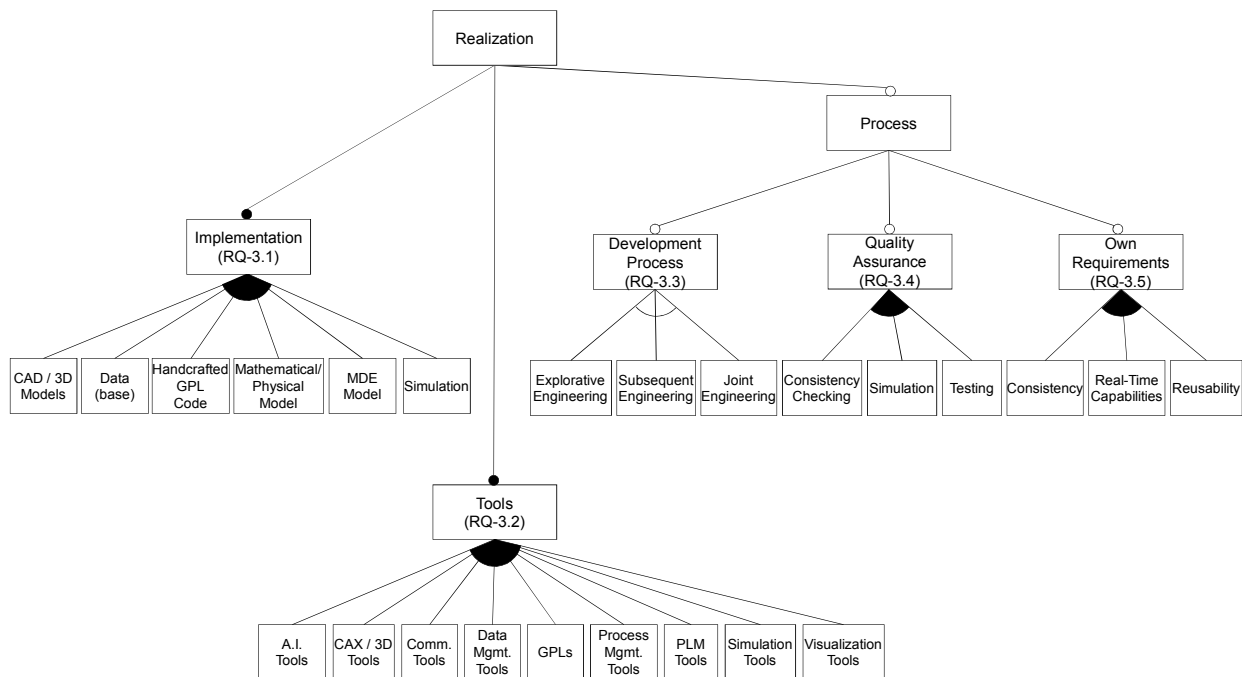

Figure 26: Engineering dimensions of Digital Twins in terms of a feature model

services. To handle the required data, data management tools may be used to engineer Digital Twins. Furthermore, CAX and 3D Tools may be used to process and provide geometric models and visualization tools for their visualization. For other simulation purposes, we found out that also general simulation tools are usable in this context. As Digital Twins are often embedded in a production environment, process management and PLM tools may also be helpful for Digital Twin engineering. Finally, communication tools and GPLs may also be used.

For Process, we differentiate between different kinds of development processes. Each product and Digital Twin is either developed jointly or isolated, with the development of the Digital Twin either frontloading the development of the product (explorative engineering) or following its development (subsequent engineering). While the development of the Digital Twin with explorative engineering is not bound to restrictions by already existing systems, the subsequent engineering of the Digital Twin has to take the constraints given by already existing systems into account but may also reuse elements and knowledge from the development of these prior systems. In contrast to these approaches, joint engineering of Digital Twin and counterpart enables to incorporate joint design decisions. Another aspect we considered under the topic of Process is quality assurance. We identified mainly three kinds of quality assurance that can be either used alone or together to assure a high quality of Digital Twins. First, consistency checking can be used to validate the information the Digital Twin uses or produces. Moreover, simulations can be used as a verification technique. Finally, also, testing as a verification and validation technique is a good method to assure a Digital Twin's quality. Apart from quality assurance, we also identified requirements specific to Digital Twins in our feature model. We identified that consistency requirement, which requires that the Digital Twin's behavior matches the behavior of their real-world counterpart, are typical requirements of Digital Twins. Moreover, real-time capabilities of Digital Twins are often required when the Digital Twin may serve a specific purpose concerning its real-time counterpart, and therefore the Digital Twin must react to events in real-time. Finally, reuse is an own Digital Twin requirement, as a new development of a Digital Twin for each physical counterpart is often unnecessary if the Digital Twin or parts of the Digital Twin are reusable.

6.3. Deployment Dimension

The deployment dimension supports the design decision to bring the Digital Twin into action and is characterized by its features shown in Figure 27. To this end, this dimension is concerned with two closely related topics, hosting

the Digital Twin in the real world and appropriate means for connecting it to its counterpart. Hosting is furthermore concerned with where the host is located, which could be the twinned system itself, a local server, or a cloud system. But hosting is also concerned with the kind of the host, as this may either be a data management system, a simulation, or even a virtual environment. When deciding about deploying a Digital Twin in the real world, it is also relevant how the Digital Twin is connected to its counterpart. While decisions about the connection of a Digital Twin are subject to its host location, various design options still exist. As such, a Digital Twin could be connected through a BUS, some other kind of local network, or even deploy Internet technology, such as respective protocols.

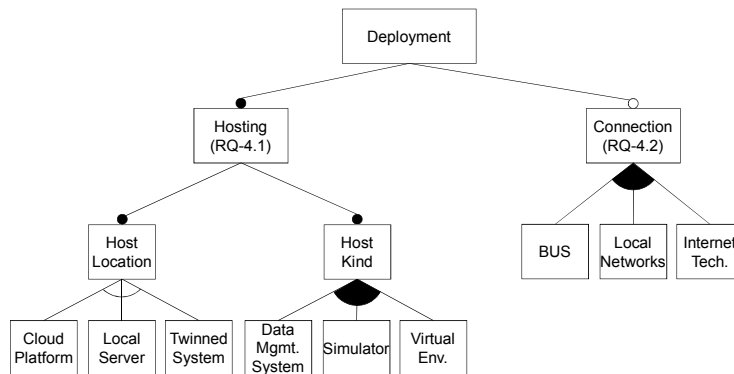

Figure 27: Deployment dimensions for Digital Twins in terms of a feature model

Decisions about the hosts' location are alternatives. A Digital Twin does mostly not live simultaneously on a twinned system and a cloud platform. Decisions here may also be subject to the type of Digital Twin to be employed and its real-world counterpart. A Digital Twin that governs a whole factory is probably not located on a local machine; vice versa, a Digital Twin that controls and monitors a single machine, may rather be deployed on the machine itself than on a cloud platform. Design decisions here should be made with the purpose of the Digital Twin in mind. In contrast, Digital Twins can support multiple host types. For example, a Digital Twin can be part of a database management system that also incorporates simulations for value updates or provides simulations as an alternative service. Furthermore, a Digital Twin deployed in a virtual environment could also function as a simulation of that twin. Finally, the connection domain provides multiple selectable options. A Digital Twin can be both connected to its counterpart through a bus and employed in a local area network.

While design decisions about the Digital Twin's deployment are important, they are mostly subject to other concerns and the available environment. The purpose of the twin affects the host location, which then limits the available connection options.

6.4. Operation Dimension

The operation dimension classifies the Digital Twin behavior while the Digital Twin is running. It specifically focuses on interaction with other systems, how the Digital Twin decides on next actions, and which kind of information it exchanges with peripheral systems. All characteristics in this dimension are optional, which means that they are not necessarily covered by all Digital Twins.

Horizontal communication encapsulates all Digital Twin communication with the main focus on information exchange where none of the involved partners can instruct another one to behave or change in a certain way. We distinguish between information exchange with PLM systems, which was frequently mentioned during our study, information exchange with the physical counterpart sharing, e.g., its current state, and even interaction with other Digital Twins. The feature decision-making specifies how the Digital Twin determines its next actions or the data that it exchanges. Machine Learning covers all Digital Twins that make predictions or decisions without being explicitly programmed only by evaluating provided data. The data mining feature characterizes Digital Twins that evaluate data sets and try to detect patterns. When Digital Twins imitate the physical world to decide on the best action, they have the simulation feature. For reasoning, we further classified Digital Twins in symbolic reasoning, numeric reasoning, and case-based reasoning. Digital Twins react to different input data and sources. These are covered by the Inputs

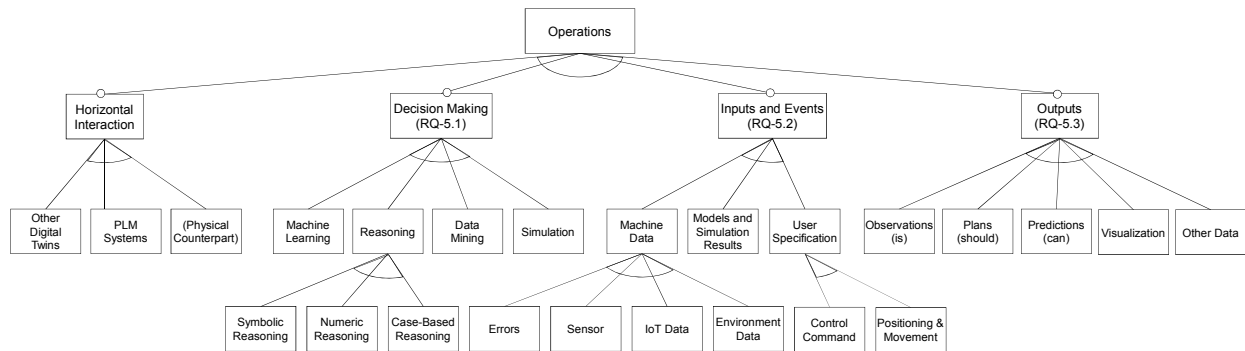

Figure 28: Operating dimensions for Digital Twins in terms of a feature model

and Events feature. Machine data can cover error logs or notifications of machines, sensor data, other IoT data, and general data about the environment in which the Digital Twin operates, e.g., temperature values in a production location. User specifications can either be given as direct control commands that are specified via a user interface, but some Digital Twins also evaluate human movements and gestures. Models and simulation results are also options for gaining knowledge about the operating context, the intended behavior, or the physical entities. The output feature describes Digital Twin outputs on a content level, so this feature does not characterize output formats or communication channels. Some Digital Twin reflect the current system state (the physical entity as it is), some Digital Twins plan how the physical entity should act in the future (the physical entity as it should be), and some Digital Twins predict the future behavior of the physical entity but do not influence it (the physical entity as it can be). Often, Digital Twins combine several of the described features to fulfill an information need or specifically optimize the underlying physical entity.

7. Threats to Validity

Our study is subject to threats to validity. In the following, we analyze and classify these according to [396] as construct, internal, external, and reliability validity. Construct validity directly refers to the study's overall design, such as search query or evaluation criteria. External threats restrict the generalizability of a study, while internal validity refers to the specificity, i.e., factors that influence the conclusions drawn from the readers. Reliability describes the trustworthiness of the study's results.

Regarding threats to the construction of this mapping study, there are plenty of similar yet distinct terms for describing Digital Twins, Digital Shadows, Virtual Twins, etc. While some publications extensively distinguish between these terms, others use them interchangeably. To ensure an accurate mapping in our study, we have considered these terms as separate concepts per default. However, if an investigated publication switched the wording while clearly referring to the Digital Twin, we followed the paper's intellectual roadmap and considered these as synonyms. Overall, this yields an accurate analysis result of the included papers. In contrast, publications using different terms only (e.g., constantly mentioning virtual copies without including the term of a Digital Twin) could not be recognized in this study, as it is impossible to extract whether the authors refer to the Digital Twin concept or explicitly distinguish from it. This topic could be addressed in a future study that explicitly includes all potential synonyms, thus covering a larger yet less precise scope.

A further threat to construct validity arises from our exclusion criteria during the initial screening of the papers, as it only considers title, keywords, and abstracts. This procedure could mistakenly exclude potentially relevant publications. To minimize this effect, we generally included papers for which we were uncertain and only excluded these in the classification phase when they turned out to be not relevant for our mapping study.

Another threat resulting from the design of our study is based on the classification of publications. In general, the categorization for several research questions is not disjoint, as a publication could be related to multiple dimensions. For instance, Digital Twins can use combinations of different techniques for decision making. This causes difficulties in evaluating the results since some dimensions may be highly interdependent. We designed the classification without

overlapping and used existing classification schemas to minimize the threat and only allow multiple assignments if necessary.

Since our work is based on a literature study, it is inevitably subject to publication bias. Principally more successes and positive reports on a topic are published. This complicates assessing the areas that are not positively affected by Digital Twins or which concepts and methods for constructing them are not applicable. Furthermore, there may be research and material outside of common research distribution channels, i.e., grey literature, which must be handled specifically [406]. Further work on the analysis of the current status of Digital Twin research could focus on grey literature.

Our study is also affected by external validity in terms of generalizability. We selected a rather general search query to obtain a large corpus of publications. Including only online-available, peer-reviewed, English publications (excluding short papers) reduces the corpus. This slightly affects generalizability, but at the same time, guarantees the accessibility of our results and the reliability of the study. As the investigated publications cover different domains and produce various findings, we cannot generally conclude that results from one problem domain apply to another. Therefore, our study elaborates on the relationships between the individual clusters to identify similarities as well as differences in a generalizable fashion.

We have used the search engines of leading scientific databases and libraries, such as SpringerLink, IEEE Xplore, ACM, WoS, and Scopus, for searching the literature. We intentionally excluded google scholar as a search engine, as it contains vast amounts of non-peer-reviewed publications (which are excluded during screening in any case). Furthermore, google scholar does not store any publications such that generally, most relevant publications are found as long as the related libraries are considered. Although this may negatively affect the external validity, it increases the reliability of the search results.

Regarding internal validity, the publications differ significantly in the level of detail in which they explain Digital Twins and their constituents. Authors often do not specify the exact system boundary of the Digital Twin, which impedes a precise mapping regarding relevant technologies. For instance, it is often obscure whether a cloud system is an integral part of the Digital Twin or whether the Digital Twin merely uses it for communication. To obtain an unambiguous mapping, we generally decided these cases in favor of the Digital Twin, attributing these properties and technologies to its realization. Additionally, controversial issues were discussed among the authors.

A further threat to internal validity is the readers' different previous knowledge, which may lead to classification discrepancies, e.g., through experience, more details can be anticipated. To minimize this effect as much as possible, we have collectively read the first 60 publications to synchronize our mapping.

The conclusions drawn from analyzing the included publications can influence the reproducibility and, thus, the study's reliability. As mentioned for internal validity, we analyzed the publications in favor of the Digital Twin to ensure an unbiased evaluation of the different sources. Another research group might draw slightly different conclusions in particular circumstances. To add transparency and to ensure a reproducible study, we explained the research method and corresponding design decisions in detail (cf. Section 3).

8. Conclusion

Our survey has shown that Digital Twins are researched in many domains, including agriculture, construction, education, mining, transportation, and for a variety of purposes. Yet, the large majority of research on Digital Twins investigates individual (cyber-physical) systems in manufacturing. We could not detect a trend that research on Digital Twins is catching up in other domains, at least in terms of the number of publications. However, advanced Digital Twins are already being presented for domains beyond manufacturing. Often, research on Digital Twins focuses on monitoring the twinned system, as well as optimizing or predicting its behavior. Where research focuses on optimizing the twinned system, the Digital Twin often acts as an outer control loop that adapts the twinned systems behavior, i.e., both systems, the twin and the twinned system, form a larger, self-adaptive system point of view. Such often emit actions, commands, or plans that directly or indirectly (e.g., via another CPS management system) control the CPS's behavior. Consequently, research on Digital Twins as-designed, as-operated, or Digital Twins addressing multiple lifecycle phases, is less common. Furthermore, current research also focuses on Digital Twins that are developed after the twinned system. Rarely, the Digital Twin and the twinned system are engineered together.

We also found relatively few research on combining AI methods with Digital Twins. Instead, to engineer and operate Digital Twins, a large variety of tools, e.g., for simulation, CAX, process management, visualization, data

management, and model-driven development, are used. The produced Digital Twins consist of models, complex subsystems (e.g., databases or dashboards), plain GPL code, and sometimes even (mostly for augmented reality components) hardware parts.

Through our survey, we also have identified and organized central design decisions common to engineering Digital Twins. These include (i) requirements on the number of twinned counterparts, when the Digital Twins should be used and which lifecycle stage of the twinned system it should represent; (ii) realization decisions regarding implementation technologies, tools, and process; and (iii) deployment decisions on the Digital Twins hosting location and its connections to the twinned system. The feature models detailing these represent the state-of-the-art decisions to consider when engineering Digital Twins. We expect future Digital Twins development to contribute further decisions to the presented feature models. Yet, they can serve researchers and practitioners as a guidance when considering Digital Twins.

Based on our observations, we identified seven challenges for the future of Digital Twin research:

1. **Domain-specific Digital Twins (RQ-1.1).** The large body of Digital Twin research focuses on a single domain, primarily manufacturing, yet other domains employ technologies that can serve as an excellent foundation for further Digital Twin research.
2. **Composable Digital Twins (RQ-2.8).** Most Digital Twins found in our survey are build from scratch. The reliable combination and composition of Digital Twins is essential for their effective (re)use. Different methods to support these processes are required. For instance, integrating the Digital Twin of a motor into the Digital Twin of a car may require another composition method than integrating the Digital Twin of a manufacturing device into the Digital Twin of a factory. For instance, building information modeling based on IFC (ISO 16739) in architecture and construction supports the integration of various concerns of Digital Twins and can be employed for many of the purposes found in our study.
3. **Standardization (RQ-3.1).** Literature yields a wide continuum of systems considered Digital Twins by the authors from various domains. These range from high-fidelity simulation models to model-less software systems operating on the twinned systems and various combinations in-between. A future, in which Digital Twins (e.g., using Digital Twins as contract parts between OEMs and suppliers) can be exchanged, combined, and integrated, requires a common understanding of the concept. Currently, there is an ISO standard for Digital Twins in manufacturing⁷ in development that might at least harmonize the understanding of Digital Twins in that domain. Whether this standard will be compatible with the understanding in other domains needs to be evaluated and technological implementations on, e.g., exchange interfaces for Digital Twins, need to follow then.
4. **Tool support (RQ-3.2).** While we have identified a large variety of tools employed to engineer and operate Digital Twins, we found very few tools specifically tailored to Digital Twins. While there are some tools mentioned in literature, such as Amazon Greengrass⁸, Eclipse Vorto⁹, or Microsoft's Digital Twin Definition Language¹⁰, these largely focus on data structure modeling and data exchange for Digital Twins but do not cover the full spectrum of modeling concerns.
5. **Modeling support (RQ-3.2).** Abstraction is the key to understanding and improving CPSs. Consequently, models are essential to Digital Twins. This is not limited to software engineering models, but includes CAD models, mathematical models, physical models, simulation models, and many more. However, modeling methods developed by software engineers are also used by professionals without formal software engineering training. Therefore, software engineering must provide methods to integrate, analyze, and transform models used in research and practice so that they can be used without software engineering background.

⁷<https://www.iso.org/standard/75066.html>

⁸<https://aws.amazon.com/de/greengrass/>

⁹<https://www.eclipse.org/vorto/>

¹⁰<https://www.aka.ms/dtdl>

6. **Quality assurance and requirements (RQ-3.4).** Digital Twins are subject to common expectation, such as to high-fidelity representation of the twinned system. Yet, we found few research on quality assurance and requirements for Digital Twins. Hence, it currently is hardly possible for a Digital Twin to fail in fulfilling requirements on it. For instance, it is left to investigate how much the fidelity of a Digital Twin may degrade before its not a (useful) Digital Twin anymore. While the feature models presented in this paper can be a starting point for exploring such requirements, these also need to build on a common understanding of the concept of Digital Twins in general.
7. **Tool selection support (RQ-3.2).** An incredible variety of methods and technologies are used in the development of Digital Twins. Identifying which methods and technologies are suitable for which challenges, requirements, and Digital Twins goals would facilitate advancing the state-of-the-art in Digital Twins. To this end, the employed methods and tools used in engineering Digital Twins need to be cross-tabulated against the purposes the these Digital Twins. Such research could result in a design catalog of technologies to achieve certain effects with Digital Twins.

To improve our insights into the software engineering for and use of digital twins, future studies on the topic should consider the evolution of concerns, tools, and methods across time. Moreover, with Digital Twins increasingly being deployed in various industries, considering including patents or gray literature from industry might yield valuable insights as well.

Overall, the study presented in this paper sheds light on the state-of-the-art in Digital Twins and on the concerns related to engineering and operating these for future research to build upon our results and for practitioners to guide their work.

Primary Studies

- [P1] F. Biesinger, D. Meike, B. Kraß, M. Weyrich, A Case Study for a Digital Twin of Body-in-White Production Systems General Concept for Automated Updating of Planning Projects in the Digital Factory, in: 23rd International Conference on Emerging Technologies and Factory Automation (ETFA), 2018.
- [P2] B. A. Talkhestani, N. Jazdi, W. Schlögl, M. Weyrich, A concept in synchronization of virtual production system with real factory based on anchor-point method, *Procedia CIRP* 67 (2018) 13–17 (2018).
- [P3] T. Kubota, C. Liu, K. Mubarak, X. Xu, A cyber-physical machine tool framework based on STEP-NC, in: *Proceedings of the 48th International Conference on Computers and Industrial Engineering (CIE)*, 2018.
- [P4] C. Liu, H. Vengayil, Y. Lu, X. Xu, A Cyber-Physical Machine Tools Platform using OPC UA and MTConnect, *Journal of Manufacturing Systems* 51 (2019) 61–74 (2019).
- [P5] P. Jain, J. Poon, J. Singh, C. Spanos, S. R. Sanders, S. K. Panda, A Digital Twin Approach for Fault Diagnosis in Distributed Photovoltaic Systems, *IEEE Transactions on Power Electronics* 35 (2020) 940–956 (2020).
- [P6] A. Padovano, F. Longo, L. Nicoletti, G. Mirabelli, A Digital Twin based Service Oriented Application for a 4.0 Knowledge Navigation in the Smart Factory, *IFAC-PapersOnLine* 51 (2018) 631–636 (2018).
- [P7] W. Ellgass, N. Holt, H. Saldana-Lemus, J. Richmond, A. Vatankhah Barenji, G. Gonzalez-Badillo, A Digital Twin Concept for Manufacturing Systems, in: *ASME International Mechanical Engineering Congress and Exposition*, 2018.
- [P8] S. Zambal, C. Eitzinger, M. Clarke, J. Klintworth, P.-Y. Mechin, A digital twin for composite parts manufacturing : Effects of defects analysis based on manufacturing data, in: 16th International Conference on Industrial Informatics (INDIN), 2018.
- [P9] P. Pileggi, J. Verriet, J. Broekhuijsen, C. van Leeuwen, W. Wijbrandi, M. Konsman, A Digital Twin for Cyber-Physical Energy Systems, in: 7th Workshop on Modeling and Simulation of Cyber-Physical Energy Systems (MSCPES), 2019.
- [P10] K. Kannan, N. Arunachalam, A Digital Twin for Grinding Wheel: An Information Sharing Platform for Sustainable Grinding Process, *Journal of Manufacturing Science and Engineering* 141 (2018).
- [P11] F. Biesinger, D. Meike, B. Kraß, M. Weyrich, A digital twin for production planning based on cyber-physical systems: A Case Study for a Cyber-Physical System-Based Creation of a Digital Twin, *Procedia CIRP* 79 (2019) 355–360 (2019).
- [P12] T. Mukherjee, T. DebRoy, A digital twin for rapid qualification of 3D printed metallic components, *Applied Materials Today* 14 (2019).
- [P13] A. Detzner, M. Eigner, et al., A digital twin for root cause analysis and product quality monitoring, in: 15th International Design Conference, 2018.
- [P14] J. Sleuters, Y. Li, J. Verriet, M. Velikova, R. Doornbos, A digital twin method for automated behavior analysis of large-scale distributed IoT systems, in: 14th Annual Conference System of Systems Engineering (SoSE), 2019.
- [P15] Y. Lu, X. Xu, A digital twin reference model for smart manufacturing, in: 48th International Conference on Computers and Industrial Engineering, 2018.
- [P16] H. Zhang, Q. Liu, X. Chen, D. Zhang, J. Leng, A Digital Twin-Based Approach for Designing and Multi-Objective Optimization of Hollow Glass Production Line, *IEEE Access* 5 (2017) 26901–26911 (2017).

- [P17] K. Josifovska, E. Yigitbas, G. Engels, A digital twin-based multi-modal ui adaptation framework for assistance systems in industry 4.0, in: *Human-Computer Interaction. Design Practice in Contemporary Societies*, 2019.
- [P18] V. Damjanovic-Behrendt, A Digital Twin-based Privacy Enhancement Mechanism for the Automotive Industry, in: *2018 International Conference on Intelligent Systems (IS)*, 2018.
- [P19] X. Sun, J. Bao, J. Li, Y. Zhang, S. Liu, B. Zhou, A digital twin-driven approach for the assembly-commissioning of high precision products, *Robotics and Computer-Integrated Manufacturing* 61 (2020) 101839 (2020).
- [P20] Y. Xu, Y. Sun, X. Liu, Y. Zheng, A Digital-Twin-Assisted Fault Diagnosis Using Deep Transfer Learning, *IEEE Access* 7 (2019) 19990–19999 (2019).
- [P21] M. Dietz, B. Putz, G. Pernul, A distributed ledger approach to digital twin secure data sharing, in: *Data and Applications Security and Privacy XXXIII*, 2019.
- [P22] C. Li, S. Mahadevan, Y. Ling, L. Wang, S. Choze, A dynamic Bayesian network approach for digital twin, in: *19th AIAA Non-Deterministic Approaches Conference*, 2017.
- [P23] D. Shangguan, L. Chen, J. Ding, A Hierarchical Digital Twin Model Framework for Dynamic Cyber-Physical System Design, in: *Proceedings of the 5th International Conference on Mechatronics and Robotics Engineering*, 2019.
- [P24] K. Dröder, P. Bobka, T. Germann, F. Gabriel, F. Dietrich, A Machine Learning-Enhanced Digital Twin Approach for Human-Robot-Collaboration, *Procedia CIRP* 76 (2018) 187–192 (2018).
- [P25] M. Ciavotta, M. Alge, S. Menato, D. Rovere, P. Pedrazzoli, A microservice-based middleware for the digital factory, *Procedia Manufacturing* 11 (2017) 931–938 (2017).
- [P26] N. Lauzeral, D. Borzacchiello, M. Kugler, D. George, Y. Rémond, A. Hostettler, F. Chinesta, A model order reduction approach to create patient-specific mechanical models of human liver in computational medicine applications, *Computer methods and programs in biomedicine* 170 (2019) 95–106 (2019).
- [P27] K. Bakliwal, M. H. Dhada, A. S. Palau, A. K. Parlikad, B. K. Lad, A Multi Agent System architecture to implement Collaborative Learning for social industrial assets, *IFAC-PapersOnLine* 51 (2018) 1237–1242 (2018).
- [P28] G. Avventuroso, M. Silvestri, P. Pedrazzoli, A Networked Production System to Implement Virtual Enterprise and Product Lifecycle Information Loops, *IFAC-PapersOnLine* 50 (2017) 7964–7969 (2017).
- [P29] T. Okita, T. Kawabata, H. Murayama, N. Nishino, M. Aichi, A new concept of digital twin of artifact systems: synthesizing monitoring/inspections, physical/numerical models, and social system models, *Procedia CIRP* 79 (2019) 667 – 672 (2019).
- [P30] Y. Liu, L. Zhang, Y. Yang, L. Zhou, L. Ren, F. Wang, R. Liu, Z. Pang, M. J. Deen, A Novel Cloud-Based Framework for the Elderly Healthcare Services Using Digital Twin, *IEEE Access* 7 (2019) 49088–49101 (2019).
- [P31] S. Kumar, R. Madhumathi, P. R. Chelliah, L. Tao, S. Wang, A novel digital twin-centric approach for driver intention prediction and traffic congestion avoidance, *Journal of Reliable Intelligent Environments* 4 (2018).
- [P32] R. Allemang, M. Spottswood, T. Eason, A principal component analysis (pca) decomposition based validation metric for use with full field measurement situations, in: *Model Validation and Uncertainty Quantification*, volume 3, 2014.
- [P33] J.-L. Gregorio, C. Lartigue, F. Thiébaud, H. Falgarone, A Reverse-Engineering Approach for the Management of Product Geometrical Variations During Assembly, in: *Advances on Mechanics, Design Engineering and Manufacturing II*, Springer, 2019.
- [P34] K. Sivalingam, M. Sepulveda, M. Spring, P. Davies, A Review and Methodology Development for Remaining Useful Life Prediction of Offshore Fixed and Floating Wind turbine Power Converter with Digital Twin Technology Perspective, in: *2018 2nd International Conference on Green Energy and Applications (ICGEA)*, 2018.
- [P35] E. L. Grange, A Roadmap for Adopting a Digital Lifecycle Approach to Offshore Oil and Gas Production, in: *OTC Offshore Technology Conference*, 2018.
- [P36] N. K. Chakshu, J. Carson, I. Sazonov, P. Nithiarasu, A semi-active human digital twin model for detecting severity of carotid stenoses from head vibration—A coupled computational mechanics and computer vision method, *International journal for numerical methods in biomedical engineering* 35 (2019) e3180 (2019).
- [P37] T. Gabor, L. Belzner, M. Kiermeier, M. T. Beck, A. Neitz, A Simulation-Based Architecture for Smart Cyber-Physical Systems, in: *2016 IEEE International Conference on Autonomic Computing (ICAC)*, 2016.
- [P38] A. Redelinghuys, A. Basson, K. Kruger, A six-layer digital twin architecture for a manufacturing cell, in: *International Workshop on Service Orientation in Holonic and Multi-Agent Manufacturing*, 2018.
- [P39] M. Eckhart, A. Ekelhart, A specification-based state replication approach for digital twins, in: *Proceedings of the 2018 Workshop on Cyber-Physical Systems Security and Privacy*, 2018.
- [P40] P. Zheng, T.-J. Lin, C.-H. Chen, X. Xu, A systematic design approach for service innovation of smart product-service systems, *Journal of Cleaner Production* 201 (2018) 657–667 (2018).
- [P41] R. Wagener, M. Scurria, T. Bein, About a digital twin for the fatigue approach of additively manufactured components, in: *TMS 2019 148th Annual Meeting & Exhibition Supplemental Proceedings*, 2019.
- [P42] R. Rosen, G. von Wichert, G. Lo, K. D. Bettenhausen, About The Importance of Autonomy and Digital Twins for the Future of Manufacturing, *IFAC-PapersOnLine* 48 (2015) 567–572 (2015).
- [P43] S. Zobel-Roos, A. Schmidt, F. Mestmäcker, M. Mouellef, M. Huter, L. Uhlenbrock, M. Kornecki, L. Lohmann, R. Ditz, J. Strube, Accelerating Biologics Manufacturing by Modeling or: Is Approval under the QbD and PAT Approaches Demanded by authorities Acceptable without a Digital-Twin?, *Processes* 7 (2019).
- [P44] G. Saini, P. Ashok, E. van Oort, M. R. Isbell, Accelerating Well Construction Using a Digital Twin Demonstrated on Unconventional Well Data in North America, in: *Unconventional Resources Technology Conference*, Houston, Texas, 23-25 July 2018, 2018.
- [P45] S. Anand, O. Ghalsasi, B. Zhang, A. Goel, S. Reddy, S. Joshi, G. Morris, Additive Manufacturing Simulation Tools in Education, in: *2018 World Engineering Education Forum-Global Engineering Deans Council (WEEF-GEDC)*, 2018.
- [P46] M. F. Milazzo, P. Bragattob, G. Ancionea, G. Sciontia, Ageing assessment and management at major-hazard industries, *Chemical Engineering* 67 (2018).
- [P47] J. Hatakeyama, D. Seal, D. Farr, S. Haase, Systems Engineering “V” in a Model-Based Engineering Environment: Is it still relevant?, in:

AIAA SPACE and Astronautics Forum and Exposition, 2018.

- [P48] Y. Zheng, S. Yang, H. Cheng, An application framework of digital twin and its case study, *Journal of Ambient Intelligence and Humanized Computing* 10 (2019) 1141–1153 (2019).
- [P49] R. Tharma, R. Winter, M. Eigner, et al., An approach for the implementation of the digital twin in the automotive wiring harness field, in: *DS 92: Proceedings of the DESIGN 2018 15th International Design Conference*, 2018.
- [P50] N. Wantia, J. Roßmann, An online task planning framework reducing execution times in industrial environments, in: *2017 4th International Conference on Industrial Engineering and Applications (ICIEA)*, 2017.
- [P51] V. Damjanovic-Behrendt, W. Behrendt, An open source approach to the design and implementation of Digital Twins for Smart Manufacturing, *International Journal of Computer Integrated Manufacturing* 32 (2019) 366–384 (2019).
- [P52] F. Yacob, D. Semere, E. Nordgren, Anomaly detection in Skin Model Shapes using machine learning classifiers, *The International Journal of Advanced Manufacturing Technology* 105 (2019).
- [P53] N. Yusupbekov, F. Abdurasulov, F. Adilov, A. Ivanyan, Application of Cloud Technologies for Optimization of Complex Processes of Industrial Enterprises, in: *International Conference on Theory and Applications of Fuzzy Systems and Soft Computing*, 2018.
- [P54] E. Sujova, H. Čierna, I. Žabińska, Application of digitization procedures of production in practice, *Management Systems in Production Engineering* 27 (2019) 23–28 (2019).
- [P55] Y. Tan, W. Yang, K. Yoshida, S. Takakuwa, Application of IoT-Aided Simulation for a Cyber-Physical System, in: *Proceedings of the 2018 Winter Simulation Conference*, 2018.
- [P56] Y. Tan, W. Yang, K. Yoshida, S. Takakuwa, Application of IoT-Aided Simulation to Manufacturing Systems in Cyber-Physical System, *Machines* 7 (2019).
- [P57] D. Mejia, A. Moreno, O. Ruiz-Salguero, I. Barandiaran, Appraisal of open software for finite element simulation of 2D metal sheet laser cut, *International Journal on Interactive Design and Manufacturing (IJIDeM)* 11 (2017) 547–558 (2017).
- [P58] A. Kychkin, A. Deryabin, O. Vikentyeva, L. Shestakova, Architecture of Compressor Equipment Monitoring and Control Cyber-Physical System Based on Influxdata Platform, in: *2019 International Conference on Industrial Engineering, Applications and Manufacturing (ICIEAM)*, 2019.
- [P59] A. Blaga, L. Tamas, Augmented reality for digital manufacturing, in: *2018 26th Mediterranean Conference on Control and Automation (MED)*, 2018.
- [P60] S. Utzig, R. Kaps, S. M. Azeem, A. Gerndt, Augmented reality for remote collaboration in aircraft maintenance tasks, in: *2019 IEEE Aerospace Conference*, 2019.
- [P61] J. Hlady, M. Glanzer, L. Fugate, Automated Creation of the Pipeline Digital Twin During Construction: Improvement to Construction Quality and Pipeline Integrity, in: *International Pipeline Conference*, 2018.
- [P62] G. S. Martínez, S. Sierla, T. Karhela, V. Vyatkin, Automatic Generation of a Simulation-Based Digital Twin of an Industrial Process Plant, in: *IECON 2018 - 44th Annual Conference of the IEEE Industrial Electronics Society*, 2018.
- [P63] Y. Kado, K. Katagiri, Autonomous Distributed Power Network Consisting of Triple Active Bridge Converters, in: *2018 Energy and Sustainability for Small Developing Economies (ES2DE)*, 2018.
- [P64] A. A. Nazarenko, L. M. Camarinha-Matos, Basis for an approach to design collaborative cyber-physical systems, in: *Technological Innovation for Industry and Service Systems*, 2019.
- [P65] C. Mandolla, A. M. Petruzzelli, G. Percoco, A. Urbinati, Building a digital twin for additive manufacturing through the exploitation of blockchain: A case analysis of the aircraft industry, *Computers in Industry* 109 (2019) 134–152 (2019).
- [P66] G. Knapp, T. Mukherjee, J. Zuback, H. Wei, T. Palmer, A. De, T. DebRoy, Building blocks for a digital twin of additive manufacturing, *Acta Materialia* 135 (2017) 390–399 (2017).
- [P67] T. Debroy, W. Zhang, J. Turner, S. S. Babu, Building digital twins of 3D printing machines, *Scripta Materialia* 135 (2017) 119–124 (2017).
- [P68] K. M. Alam, A. El Saddik, C2PS: A Digital Twin Architecture Reference Model for the Cloud-Based Cyber-Physical Systems, *IEEE Access* 5 (2017) 2050–2062 (2017).
- [P69] M. Trancossi, M. Cannistraro, J. Pascoa, Can constructal law and exergy analysis produce a robust design method that couples with industry 4.0 paradigms? The case of a container house, *Mathematical Modelling of Engineering Problems* 5 (2018) 303–312 (2018).
- [P70] M. Eisenträger, S. Adler, M. Kennel, S. Möser, Changeability in Engineering, in: *2018 IEEE International Conference on Engineering, Technology and Innovation (ICE/ITMC)*, 2018.
- [P71] B. Gockel, A. Tudor, M. Brandyberry, R. Penmettsa, E. Tuegel, Challenges with structural life forecasting using realistic mission profiles, in: *53rd AIAA/ASME/ASCE/AHS/ASC Structures, Structural Dynamics and Materials Conference 20th AIAA/ASME/AHS Adaptive Structures Conference 14th AIAA*, 2012.
- [P72] M. Di Maio, G.-D. Kapos, N. Klusmann, L. Atorf, U. Dahmen, M. Schluse, J. Rossmann, Closed-Loop Systems Engineering (CLOSE): Integrating Experimentable Digital Twins with the Model-Driven Engineering Process., in: *2018 IEEE International Systems Engineering Symposium (ISSE)*, 2018.
- [P73] M. Weiss, V. Tuncay, S. Richter, J. Broz, Comprehensive Simulation and Connected Intelligence in Thermal Management Systems, *MTZ worldwide* 78 (2017) 36–41 (2017).
- [P74] W. V. Mars, J. D. Suter, M. Bauman, Computing Remaining Fatigue Life Under Incrementally Updated Loading Histories, in: *WCX World Congress Experience*, 2018.
- [P75] B. A. Talkhestani, N. Jazdi, W. Schloegl, M. Weyrich, Consistency check to synchronize the Digital Twin of manufacturing automation based on anchor points, *Procedia CIRP* 72 (2018) 159–164 (2018).
- [P76] S.-J. Song, Y.-G. Jang, Construction of Digital Twin Geotechnical Resistance Model for Liquefaction Risk Evaluation, in: *2nd International Symposium on Computer Science and Intelligent Control*, 2018.
- [P77] K. Rambow-Hoeschele, A. Nagl, D. K. Harrison, B. M. Wood, K. Bozem, K. Braun, P. Hoch, Creation of a digital business model builder, in: *IEEE International Conference on Engineering, Technology and Innovation (ICE/ITMC)*, 2018.
- [P78] E. Frontoni, J. Loncarski, R. Pierdicca, M. Bernardini, M. Sasso, Cyber physical systems for industry 4.0: Towards real time virtual reality in smart manufacturing, in: *Augmented Reality, Virtual Reality, and Computer Graphics*, 2018.

- [P79] A. R. Al-Ali, R. Gupta, A. A. Nabulsi, Cyber physical systems role in manufacturing technologies, *AIP Conference Proceedings* 1957 (2018) 050007 (2018).
- [P80] F. Arafsha, F. Laamarti, A. El Saddik, Cyber-Physical System Framework for Measurement and Analysis of Physical Activities, *Electronics* 8 (2019).
- [P81] M. Armendia, T. Fuertjes, D. Plakhotnik, J. Sossenheimer, D. Flum, Cyber-Physical System to Improve Machining Process Performance, in: *Twin-Control*, Springer, 2019.
- [P82] R. Bohlin, J. Hagmar, K. Bengtsson, L. Lindkvist, J. S. Carlson, R. Söderberg, Data Flow and Communication Framework Supporting Digital Twin for Geometry Assurance, in: *International Mechanical Engineering Congress and Exposition*, 2017.
- [P83] S. Yun, J.-H. Park, W.-T. Kim, Data-centric middleware based digital twin platform for dependable cyber-physical systems, in: *2017 Ninth International Conference on Ubiquitous and Future Networks (ICUFN)*, 2017.
- [P84] N. Stojanovic, D. Milenovic, Data-driven Digital Twin approach for process optimization: an industry use case, in: *2018 IEEE International Conference on Big Data (Big Data)*, 2018.
- [P85] R. He, G. Chen, C. Dong, S. Sun, X. Shen, Data-driven digital twin technology for optimized control in process systems, *ISA transactions* 95 (2019) 221–234 (2019).
- [P86] A. Coraddu, L. Oneto, F. Baldi, F. Cipollini, M. Atlas, S. Savio, Data-driven ship digital twin for estimating the speed loss caused by the marine fouling, *Ocean Engineering* 186 (2019).
- [P87] F. Oquendo, Dealing with Uncertainty in Software Architecture on the Internet-of-Things with Digital Twins, in: *International Conference on Computational Science and Its Applications*, 2019.
- [P88] R. Dong, C. She, W. Hardjawana, Y. Li, B. Vucetic, Deep learning for hybrid 5G services in mobile edge computing systems: Learn from a digital twin, *IEEE Transactions on Wireless Communications* 18 (2019) 4692–4707 (2019).
- [P89] K. Ding, F. T. Chan, X. Zhang, G. Zhou, F. Zhang, Defining a Digital Twin-based Cyber-Physical Production System for autonomous manufacturing in smart shop floors, *International journal of Production Research* 57 (2019) 6315–6334 (2019).
- [P90] J. M. Eyre, T. J. Dodd, C. Freeman, R. Lanyon-Hogg, A. J. Lockwood, R. W. Scott, Demonstration of an industrial framework for an implementation of a process digital twin, in: *ASME 2018 International Mechanical Engineering Congress and Exposition*, 2018.
- [P91] R. Bitton, T. Gluck, O. Stan, M. Inokuchi, Y. Ohta, Y. Yamada, T. Yagy, Y. Elovici, A. Shabtai, Deriving a Cost-Effective Digital Twin of an ICS to Facilitate Security Evaluation, in: *Computer Security*, 2018.
- [P92] K. T. Park, Y. W. Nam, H. S. Lee, S. J. Im, S. D. Noh, J. Y. Son, H. Kim, Design and implementation of a digital twin application for a connected micro smart factory, *International journal of Computer Integrated Manufacturing* 32 (2019).
- [P93] B. Jeon, S.-H. Suh, Design Considerations and Architecture for Cooperative Smart Factory: MAPE/BD Approach, *Procedia Manufacturing* 26 (2018) 1094–1106 (2018).
- [P94] C. Marty, J. Yu, G. Martin, R. Bornoff, A. Poppe, D. Fournier, E. Morard, Design flow for the development of optimized LED luminaires using multi-domain compact model simulations, in: *2018 24rd International Workshop on Thermal Investigations of ICs and Systems (THERMINIC)*, 2018.
- [P95] M. Uzun, M. U. Demirezen, E. Koyuncu, G. Inalhan, Design of a hybrid digital-twin flight performance model through machine learning, in: *2019 IEEE Aerospace Conference*, 2019.
- [P96] P. P. Pereverzev, A. V. Akintseva, M. K. Alsigar, D. V. Ardashev, Designing optimal automatic cycles of round grinding based on the synthesis of digital twin technologies and dynamic programming method, *Mechanical Sciences* 10 (2019) 331–341 (2019).
- [P97] D. Renzi, D. Maniar, S. McNeill, C. Del Vecchio, et al., Developing a digital twin for floating production systems integrity management, in: *OTC Brasil*, 2017.
- [P98] D. Shcherba, A. Tarasov, A. I. Borovkov, Developing of phenomenological damage model for automotive low-carbon structural steel for using in validation of euroncap frontal impact, *Materials Physics and Mechanics* 40 (2018) 246–253 (2018).
- [P99] R. A. Khakimov, N. S. Shcherbo, Development and creation a model of a digital twin of the cubepart rectification installation for the separation of a binary water-alcohol mixture, *IOP Conference Series: Materials Science and Engineering* 450 (2018).
- [P100] A. Carbonari, L. Messi, B. Naticchia, M. Vaccarini, M. Pirani, Development of a BIM-based holonic system for real-time monitoring of building operational efficiency, *Frontiers of Engineering Management* 7 (2020) 89–103 (2020).
- [P101] C.-S. Shim, N.-S. Dang, S. Lon, C.-H. Jeon, Development of a bridge maintenance system for prestressed concrete bridges using 3D digital twin model, *Structure and Infrastructure Engineering* 15 (2019) 1319–1332 (2019).
- [P102] Y. Umeda, J. Ota, F. Kojima, M. Saito, H. Matsuzawa, T. Sukekawa, A. Takeuchi, K. Makida, S. Shirafuji, Development of an education program for digital manufacturing system engineers based on ‘Digital Triplet’ concept, *Procedia Manufacturing* 31 (2019) 363–369 (2019).
- [P103] J. Gomez-Escalonilla, D. Garijo, O. Valencia, I. Rivero, Development of efficient high-fidelity solutions for virtual fatigue testing, in: *ICAF 2019 – Structural Integrity in the Age of Additive Manufacturing*, 2020.
- [P104] X. Chen, E. Kang, S. Shiraiishi, V. M. Preciado, Z. Jiang, Digital behavioral twins for safe connected cars, in: *Proceedings of the 21th ACM/IEEE International Conference on Model Driven Engineering Languages and Systems*, 2018.
- [P105] F. Ameri, R. Sabbagh, Digital factories for capability modeling and visualization, in: *Advances in Production Management Systems. Initiatives for a Sustainable World*, 2016.
- [P106] A. Thomas, D. A. Guerra-Zubiaga, J. Cohran, Digital Factory: Simulation Enhancing Production and Engineering Process, in: *ASME International Mechanical Engineering Congress and Exposition*, 2018.
- [P107] C. Block, B. Kuhlentötter, Digital factory implementation approach starting from the macroscopic perspective with an example for holistic planning in assembly systems, in: *Advances in Production Research*, 2019.
- [P108] W. N. Dawes, N. Meah, A. Kudryavtsev, R. Evans, M. Hunt, P. Tiller, Digital Geometry to Support a Gas Turbine Digital Twin, in: *AIAA Scitech 2019 Forum*, 2019.
- [P109] F. Lima, C. N. De Carvalho, M. B. Acardi, E. G. Dos Santos, G. B. De Miranda, R. F. Maia, A. A. Massote, Digital manufacturing tools in the simulation of collaborative robots: towards industry 4.0, *Brazilian journal of Operations & Production Management* 16 (2019) 261–280 (2019).
- [P110] G. Shao, D. Kibira, Digital Manufacturing: Requirements and Challenges for Implementing Digital Surrogates, in: *2018 Winter Simulation*

- Conference (WSC), 2018.
- [P111] J. V. Zueber, R. Kolonay, P. Kobryn, E. J. Tuegel, Digital thread and Twin for systems engineering: pre-MDD through TMRR, in: 55th AIAA Aerospace Sciences Meeting, American Institute of Aeronautics and Astronautics, 2017.
- [P112] C. Geselschap, G. Meskers, R. V. Dijk, I. V. Winsen, Digital Twin - Engineering with the Human Factor in the Loop, in: Offshore Technology Conference, 2019.
- [P113] S. Kaewunruen, Q. Lian, Digital twin aided sustainability-based lifecycle management for railway turnout systems, *Journal of Cleaner Production* 228 (2019) 1537–1551 (2019).
- [P114] D. Iglesias, P. Bunting, S. Esquembri, J. Hollocombe, S. Silburn, L. Vitton-Mea, I. Balboa, A. Huber, G. Matthews, V. Riccardo, F. Rimini, D. Valcarcel, Digital twin applications for the JET divertor, *Fusion Engineering and Design* 125 (2017) 71–76 (2017).
- [P115] D. Kostenko, N. Kudryashov, M. Maystrishin, V. Onufriev, V. Potekhin, A. Vasiliev, DIGITAL TWIN APPLICATIONS: DIAGNOSTICS, OPTIMISATION AND PREDICTION., *Annals of DAAAM & Proceedings* 29 (2018).
- [P116] K. A. Kurniadi, S. Lee, K. Ryu, Digital twin approach for solving reconfiguration planning problems in rms, in: *Advances in Production Management Systems. Smart Manufacturing for Industry 4.0*, 2018.
- [P117] B. Brenner, V. Hummel, Digital Twin as Enabler for an Innovative Digital Shopfloor Management System in the ESB Logistics Learning Factory at Reutlingen - University, *Procedia Manufacturing* 9 (2017) 198–205 (2017).
- [P118] V. Kuts, T. Otto, T. Tähemaa, Y. Bondarenko, Digital twin based synchronised control and simulation of the industrial robotic cell using virtual reality, *Journal of Machine Engineering* 19 (2019).
- [P119] Y. Liao, H. Lee, K. Ryu, Digital Twin concept for smart injection molding, *IOP Conference Series: Materials Science and Engineering* 324 (2018) 012077 (2018).
- [P120] G. N. Schroeder, C. Steinmetz, C. E. Pereira, D. B. Espindola, Digital Twin Data Modeling with AutomationML and a Communication Methodology for Data Exchange, *IFAC-PapersOnLine* 49 (2016) 12 – 17 (2016).
- [P121] I. Raineri, F. La Mura, H. Giberti, Digital Twin Development of HexaFloat, a 6DoF PKM for HIL Tests, in: *The International Conference of IFToMM ITALY*, 2018.
- [P122] W. Luo, T. Hu, C. Zhang, Y. Wei, Digital twin for CNC machine tool: modeling and using strategy, *Journal of Ambient Intelligence and Humanized Computing* 10 (2019) 1129–1140 (2019).
- [P123] L. Pivano, D. T. Nguyen, K. Bruun Ludvigsen, Digital Twin for Drilling Operations – Towards Cloud-Based Operational Planning, in: *Offshore Technology Conference*, 2019.
- [P124] N. Karanjkar, A. Joglekar, S. Mohanty, V. Prabhu, D. Raghunath, R. Sundaresan, Digital twin for energy optimization in an SMT-PCB assembly line, in: *2018 IEEE International Conference on Internet of Things and Intelligence System (IOTAIS)*, 2018.
- [P125] K. Vijayakumar, C. Dhanasekaran, R. Pugazhenthii, S. Sivaganesan, Digital Twin for factory system simulation, *International Journal of Recent Technology and Engineering* 8 (2019) 63–68 (2019).
- [P126] A. Khan, M. Dahl, P. Falkman, M. Fabian, Digital Twin for Legacy Systems: Simulation Model Testing and Validation, in: *2018 IEEE 14th International Conference on Automation Science and Engineering (CASE)*, 2018.
- [P127] Q. Qiao, J. Wang, L. Ye, R. X. Gao, Digital Twin for machining tool condition prediction, *Procedia CIRP* 81 (2019) 1388–1393 (2019).
- [P128] J. Wang, L. Ye, R. X. Gao, C. Li, L. Zhang, Digital Twin for rotating machinery fault diagnosis in smart manufacturing, *International Journal of Production Research* 57 (2019) 3920–3934 (2019).
- [P129] S. Kaewunruen, N. Xu, Digital twin for sustainability evaluation of railway station buildings, *Frontiers in Built Environment* 4 (2018) 77 (2018).
- [P130] X. Fei, Q. Fengchen, S. Bing, F. Yuzhu, Digital Twin of Solid Rocket Motor, Problem and Challenge, in: *2018 11th International Symposium on Computational Intelligence and Design (ISCID)*, 2018.
- [P131] S. KOSENKOV, V. Y. TURCHANINOV, I. Korovin, D. Y. IVANOV, Digital Twin of the Oil Well, Based on Data Mining Technologies, in: *2nd International Conference on Modeling, Simulation and Optimization Technologies and Applications (MSOTA)*, 2018.
- [P132] Q. Qi, F. Tao, Y. Zuo, D. Zhao, Digital Twin Service towards Smart Manufacturing, *Procedia CIRP* 72 (2018) 237–242 (2018).
- [P133] F. Tao, M. Zhang, Digital Twin Shop-Floor: A New Shop-Floor Paradigm Towards Smart Manufacturing, *IEEE Access* 5 (2017) 20418–20427 (2017).
- [P134] R. Anderl, S. Haag, K. Schützer, E. Zancul, Digital twin technology—An approach for Industrie 4.0 vertical and horizontal lifecycle integration, *IT-Information Technology* 60 (2018) 125–132 (2018).
- [P135] T. Brewer, D. Knight, G. Noiray, H. Naik, Digital Twin Technology in the Field Reclaims Offshore Resources, in: *Offshore Technology Conference*, 2019.
- [P136] K. Yan, W. Xu, B. Yao, Z. Zhou, D. T. Pham, Digital twin-based energy modeling of industrial robots, in: *Asian Simulation Conference*, 2018.
- [P137] R. H. Guerra, R. Quiza, A. Villalonga, J. Arenas, F. Castaño, Digital Twin-Based Optimization for Ultraprecision Motion Systems With Backlash and Friction, *IEEE Access* 7 (2019) 93462–93472 (2019).
- [P138] J. Liu, H. Zhou, G. Tian, X. Liu, X. Jing, Digital twin-based process reuse and evaluation approach for smart process planning, *The International Journal of Advanced Manufacturing Technology* 100 (2019) 1619–1634 (2019).
- [P139] C. Zhuang, J. Liu, H. Xiong, Digital twin-based smart production management and control framework for the complex product assembly shop-floor, *The International Journal of Advanced Manufacturing Technology* 96 (2018) 1149–1163 (2018).
- [P140] X. V. Wang, L. Wang, Digital twin-based WEEE recycling, recovery and remanufacturing in the background of Industry 4.0, *International Journal of Production Research* 57 (2019) 3892–3902 (2019).
- [P141] S. Meng, S. Tang, Y. Zhu, C. Chen, Digital twin-driven control method for robotic automatic assembly system, in: *IOP Conference Series: Materials Science and Engineering*, 2019.
- [P142] H. Zhang, G. Zhang, Q. Yan, Digital twin-driven cyber-physical production system towards smart shop-floor, *Journal of Ambient Intelligence and Humanized Computing* 10 (2019) 4439–4453 (2019).
- [P143] R. Zhao, D. Yan, Q. Liu, J. Leng, J. Wan, X. Chen, X. Zhang, Digital Twin-Driven Cyber-Physical System for Autonomously Controlling of Micro Punching System, *IEEE Access* 7 (2019) 9459–9469 (2019).

- [P144] J. Leng, H. Zhang, D. Yan, Q. Liu, X. Chen, D. Zhang, Digital twin-driven manufacturing cyber-physical system for parallel controlling of smart workshop, *Journal of Ambient Intelligence and Humanized Computing* 10 (2019) 1155–1166 (2019).
- [P145] F. Tao, F. Sui, A. Liu, Q. Qi, M. Zhang, B. Song, Z. Guo, S. C.-Y. Lu, A. Y. C. Nee, Digital twin-driven product design framework, *International Journal of Production Research* 57 (2019) 3935–3953 (2019).
- [P146] F. Tao, J. Cheng, Q. Qi, M. Zhang, H. Zhang, F. Sui, Digital twin-driven product design, manufacturing and service with big data, *The International Journal of Advanced Manufacturing Technology* 94 (2018) 3563–3576 (2018).
- [P147] Q. Liu, H. Zhang, J. Leng, X. Chen, Digital twin-driven rapid individualised designing of automated flow-shop manufacturing system, *International Journal of Production Research* 57 (2019) 3903–3919 (2019).
- [P148] M. Ayani, M. Ganebäck, A. H. Ng, Digital Twin: Applying emulation for machine reconditioning, *Procedia CIRP* 72 (2018) 243–248 (2018).
- [P149] R. Lu, I. Brilakis, Digital twinning of existing reinforced concrete bridges from labelled point clusters, *Automation in Construction* 105 (2019) 102837 (2019).
- [P150] F. Tao, Q. Qi, L. Wang, A. Nee, Digital Twins and Cyber-Physical Systems toward Smart Manufacturing and Industry 4.0: Correlation and Comparison, *Engineering* 5 (2019) 653–661 (2019).
- [P151] J. Kaivo-oja, O. Kuusi, M. S. Knudsen, T. Lauraeus, Digital Twins Approach and Future Knowledge Management Challenges: Where We Shall Need System Integration, Synergy Analyses and Synergy Measurements?, in: *International Conference on Knowledge Management in Organizations*, 2019.
- [P152] L. Rauch, M. Pietrzyk, Digital twins as a modern approach to design of industrial processes, *Journal of Machine Engineering* 19 (2019).
- [P153] W. Kuehn, Digital twins for decision making in complex production and logistic enterprises, *International Journal of Design & Nature and Ecodynamics* 13 (2018) 260–271 (2018).
- [P154] H. Brandtstaedter, C. Ludwig, L. Hübner, E. Tsouchnika, A. Jungiewicz, U. Wever, DIGITAL TWINS FOR LARGE ELECTRIC DRIVE TRAINS, in: *2018 Petroleum and Chemical Industry Conference Europe (PCIC Europe)*, 2018.
- [P155] K. Bruynseels, F. Santoni de Sio, J. van den Hoven, Digital twins in health care: ethical implications of an emerging engineering paradigm, *Frontiers in Genetics* 9 (2018) 31 (2018).
- [P156] H.-D. Wuttke, K. Henke, R. Hutschenreuter, Digital Twins in Remote Labs, in: *International Conference on Remote Engineering and Virtual Instrumentation*, 2019.
- [P157] A. A. Malik, A. Bilberg, Digital twins of human robot collaboration in a production setting, *Procedia Manufacturing* 17 (2018) 278–285 (2018).
- [P158] F. Jaensch, A. Csiszar, C. Scheifele, A. Verl, Digital Twins of Manufacturing Systems as a Base for Machine Learning, in: *2018 25th International Conference on Mechatronics and Machine Vision in Practice (M2VIP)*, 2018.
- [P159] A. A. Malozemov, V. N. Bondar, V. V. Egorov, G. A. Malozemov, Digital twins technology for internal combustion engines development, in: *2018 Global Smart Industry Conference (GloSIC)*, 2018.
- [P160] F. Caputo, A. Greco, M. Fera, R. Macchiaroli, Digital twins to enhance the integration of ergonomics in the workplace design, *International Journal of Industrial Ergonomics* 71 (2019) 20–31 (2019).
- [P161] T. Cichon, J. Roßmann, Digital Twins: Assisting and Supporting Cooperation in Human-Robot Teams, in: *2018 15th International Conference on Control, Automation, Robotics and Vision (ICARCV)*, 2018.
- [P162] A. El Saddik, Digital twins: The convergence of multimedia technologies, *IEEE multimedia* 25 (2018) 87–92 (2018).
- [P163] A. A. Malik, A. Bilberg, Digital twins of human robot collaboration in a production setting, *Procedia Manufacturing* 17 (2018) 278–285 (2018).
- [P164] Y. Shi, J. Xu, W. Du, Discussion on the New Operation Management Mode of Hydraulic Engineering Based on the Digital Twin Technique, in: *Journal of Physics: Conference Series*, 2019.
- [P165] D. Nadhan, M. G. Mayani, R. Rommetveit, Drilling with Digital Twins, in: *IADC/SPE Asia Pacific Drilling Technology Conference and Exhibition*, 2018.
- [P166] J. Liu, H. Zhou, X. Liu, G. Tian, M. Wu, L. Cao, W. Wang, Dynamic Evaluation Method of Machining Process Planning Based on Digital Twin, *IEEE Access* (2019).
- [P167] H. Zhang, G. Zhang, Q. Yan, Dynamic resource allocation optimization for digital twin-driven smart shopfloor, in: *2018 IEEE 15th International Conference on Networking, Sensing and Control (ICNSC)*, 2018.
- [P168] G. Wiegand, C. Mai, Y. Liu, H. Hußmann, Early Take-Over Preparation in Stereoscopic 3D, in: *10th International Conference on Automotive User Interfaces and Interactive Vehicular Applications*, 2018.
- [P169] A. Peuhkurinen, T. Mikkonen, Embedding web apps in mixed reality, in: *2018 Third International Conference on Fog and Mobile Edge Computing (FMEC)*, 2018.
- [P170] O. J. Pinon, D. J. Siedlak, D. Mavris, Enabling the Digital Factory through the Integration of Data-Driven and Simulation Models, in: *31st Congress of the International Council of the Aeronautical Sciences (ICAS)*, 2018.
- [P171] J. Kraft, S. Kuntzagk, Engine Fleet-Management: The Use of Digital Twins From a MRO Perspective, in: *Turbo Expo: Power for Land, Sea, and Air*, 2017.
- [P172] M. Zhang, Y. Zuo, F. Tao, Equipment energy consumption management in digital twin shop-floor: A framework and potential applications, in: *2018 IEEE 15th International Conference on Networking, Sensing and Control (ICNSC)*, 2018.
- [P173] D. Duplák, M. Flímel, J. Duplák, M. Hatala, S. Radchenko, F. Botko, Ergonomic rationalization of lighting in the working environment. Part I.: Proposal of rationalization algorithm for lighting redesign, *International Journal of Industrial Ergonomics* 71 (2019) 92–102 (2019).
- [P174] Z. Tian, S. Gregson, Examination of the Effectiveness of Mode Orthogonalisation and Filtering for Scattering Suppression in Antenna Measurements Through Computational Electromagnetic Simulation, in: *2019 13th European Conference on Antennas and Propagation (EuCAP)*, 2019.
- [P175] U. Dahmen, J. Rossmann, Experimentable Digital Twins for a Modeling and Simulation-based Engineering Approach, in: *2018 IEEE International Systems Engineering Symposium (ISSE)*, 2018.
- [P176] M. Schluse, M. Priggemeyer, L. Atorf, J. Rossmann, Experimentable digital twins—Streamlining simulation-based systems engineering

- for industry 4.0, *IEEE Transactions on Industrial Informatics* 14 (2018) 1722–1731 (2018).
- [P177] V. Kuts, G. E. Modoni, W. Terkaj, T. Tähemaa, M. Sacco, T. Otto, Exploiting factory telemetry to support virtual reality simulation in robotics cell, in: *Augmented Reality, Virtual Reality, and Computer Graphics*, 2017.
- [P178] A. Bekker, Exploring the blue skies potential of digital twin technology for a polar supply and research vessel, in: *Proceedings of the 13th International Marine Design Conference Marine Design XIII (IMDC 2018)*, 2018.
- [P179] M. Peruzzini, F. Grandi, M. Pellicciari, Exploring the potential of Operator 4.0 interface and monitoring, *Computers & Industrial Engineering* 139 (2020) 105600 (2020).
- [P180] I. Verner, M. Reitman, D. Cupeerman, T. Yan, E. Finkelstein, T. Romm, Exposing robot learning to students in augmented reality experience, in: *Smart Industry & Smart Education*, 2019.
- [P181] F. Laborie, O. C. Røed, G. Engdahl, A. Camp, Extracting Value from Data Using an Industrial Data Platform to Provide a Foundational Digital Twin, in: *Offshore Technology Conference*, 2019.
- [P182] V. Zhidchenko, I. Malysheva, H. Handroos, A. Kovartsev, Faster than real-time simulation of mobile crane dynamics using digital twin concept, *Journal of Physics: Conference Series* 1096 (2018).
- [P183] V. Zaccaria, M. Stenfelt, I. Aslanidou, K. G. Kyprianidis, Fleet monitoring and diagnostics framework based on digital twin of aero-engines, in: *Turbo Expo: Power for Land, Sea, and Air*, 2018.
- [P184] A. V. Gurjanov, D. A. Zakoldaev, A. V. Shukalov, I. O. Zharinov, Formation principles of digital twins of Cyber-Physical Systems in the smart factories of Industry 4.0, in: *IOP Conference Series: Materials Science and Engineering*, 2019.
- [P185] J. Ríos, F. M. Morate, M. Oliva, J. C. Hernández, Framework to support the aircraft digital counterpart concept with an industrial design view, *International Journal of Agile Systems and Management* 9 (2016) 212–231 (2016).
- [P186] M. Schluse, J. Rossmann, From simulation to experimentable digital twins: Simulation-based development and operation of complex technical systems, in: *2016 IEEE International Symposium on Systems Engineering (ISSE)*, 2016.
- [P187] Y. He, J. Guo, X. Zheng, From surveillance to digital twin: Challenges and recent advances of signal processing for industrial internet of things, *IEEE Signal Processing Magazine* 35 (2018) 120–129 (2018).
- [P188] G. Grinshpun, T. Cichon, D. Dipika, J. Rossmann, From Virtual Testbeds to Real Lightweight Robots: Development and deployment of control algorithms for soft robots, with particular reference to, in: *Proceedings of ISR 2016: 47st International Symposium on Robotics*, 2016.
- [P189] J. Goldmeier, W. York, P. Glaser, Fuel and Combustion System Capabilities of GE's F and HA Class Gas Turbines, in: *Turbo Expo: Power for Land, Sea, and Air*, 2017.
- [P190] B. Schleich, K. Wärmefjord, R. Söderberg, S. Wartzack, Geometrical Variations Management 4.0: towards next Generation Geometry Assurance, *Procedia CIRP* 75 (2018) 3–10 (2018).
- [P191] A. Fricke, H. Asche, Geospatial database for the generation of multidimensional virtual city models dedicated to urban analysis and decision-making, in: *Computational Science and Its Applications – ICCSA 2019*, 2019.
- [P192] Z. Forgo, A. Hypki, B. Kuhlenkoetter, Gesture based robot programming using ROS platform, in: *ISR 2018; 50th International Symposium on Robotics*, 2018.
- [P193] G. Horváth, G. Erdős, Gesture Control of Cyber Physical Systems, *Procedia CIRP* 63 (2017) 184–188 (2017).
- [P194] C. Dufour, Z. Soghomonian, W. Li, Hardware-in-the-loop testing of modern on-board power systems using digital twins, in: *2018 International Symposium on Power Electronics, Electrical Drives, Automation and Motion (SPEEDAM)*, 2018.
- [P195] A. K. Ghosh, S. U. AMM, A. Kubo, Hidden Markov model-based digital twin construction for futuristic manufacturing systems, *Artificial Intelligence for Engineering Design, Analysis and Manufacturing: AI EDAM* 33 (2019) 317–331 (2019).
- [P196] Y. Wang, M. Dittmann, R. Anderl, Holistic scenarios by using platform technologies for small batch-sized production, in: *Advances in Neuroergonomics and Cognitive Engineering*, 2019.
- [P197] T. Stachowski, H. Kjeilen, Holistic ship design—How to utilise a digital twin in concept design through basic and detailed design, in: *International Conference on Computer Applications in Shipbuilding*, 2017.
- [P198] D. Morais, M. Waldie, et al., How to implement tech in shipbuilding: Charting the course to success, in: *SNAME Maritime Convention*, 2018.
- [P199] C. Savur, S. Kumar, S. Arora, T. Hazbar, F. Sahin, HRC-SoS: Human robot collaboration experimentation platform as system of systems, in: *2019 14th Annual Conference System of Systems Engineering (SoSE)*, 2019.
- [P200] T. Petković, D. Puljiz, I. Marković, B. Hein, Human intention estimation based on hidden Markov model motion validation for safe flexible robotized warehouses, *Robotics and Computer-Integrated Manufacturing* 57 (2019) 182–196 (2019).
- [P201] E. Y. Song, M. Burns, A. Pandey, T. Roth, IEEE 1451 Smart Sensor Digital Twin Federation for IoT/CPS Research, in: *IEEE Sensors Applications Symposium (SAS)*, 2019.
- [P202] P. Dziurzanski, J. Swan, L. S. Indrusiak, J. M. Ramos, Implementing Digital Twins of Smart Factories with Interval Algebra, in: *IEEE International Conference on Industrial Technology (ICIT)*, 2019.
- [P203] S. Yun, J.-h. Park, H.-s. Kim, W.-T. Kim, Importance-aware SDN Control Mechanism for Real-time Data Distribution Services, in: *2018 International Conference on Information and Communication Technology Convergence (ICTC)*, 2018.
- [P204] P. Pereverzev, A. Akintseva, M. Alsigar, Improvement of the quality of designed cylindrical grinding cycle with traverse feeding based on the use of digital twin options, in: *MATEC Web of Conferences*, 2018.
- [P205] H. Y. Jeon, C. Justin, D. N. Mavris, Improving Prediction Capability of Quadcopter Through Digital Twin, in: *AIAA Scitech 2019 Forum*, 2019.
- [P206] N. Teslya, Industrial socio-cyberphysical system's consumables tokenization for smart contracts in blockchain, in: *Business Information Systems Workshops*, 2019.
- [P207] J. Vatn, Industry 4.0 and real-time synchronization of operation and maintenance, in: *Safety and Reliability-Safe Societies in a Changing World-Proceedings of the 28th International European Safety and Reliability Conference, ESREL 2018*, 2018.
- [P208] J. Reitz, M. Schluse, J. Roßmann, Industry 4.0 beyond the factory: An application to forestry, in: *Tagungsband des 4. Kongresses Montage Handhabung Industrieroboter*, 2019.

- [P209] C. Moussa, K. Ai-Haddad, B. Kedjar, A. Merkhouf, Insights into Digital Twin Based on Finite Element Simulation of a Large Hydro Generator, in: IECON 2018 - 44th Annual Conference of the IEEE Industrial Electronics Society, 2018.
- [P210] K. Wärmefjord, R. Söderberg, L. Lindkvist, B. Lindau, J. S. Carlson, Inspection data to support a digital twin for geometry assurance, in: ASME international mechanical engineering congress and exposition, 2017.
- [P211] W. D. Lin, Y. H. Low, Y. T. Chong, C. L. Teo, Integrated Cyber Physical Simulation Modelling Environment for Manufacturing 4.0, in: 2018 IEEE International Conference on Industrial Engineering and Engineering Management (IEEM), 2018.
- [P212] M. Kunath, H. Winkler, Integrating the Digital Twin of the manufacturing system into a decision support system for improving the order management process, *Procedia CIRP* 72 (2018) 225–231 (2018).
- [P213] I. Graessler, A. Poehler, Integration of a digital twin as human representation in a scheduling procedure of a cyber-physical production system, in: 2017 IEEE International Conference on Industrial Engineering and Engineering Management (IEEM), 2017.
- [P214] H. Pargmann, D. Euhausen, R. Faber, Intelligent big data processing for wind farm monitoring and analysis based on cloud-technologies and digital twins: A quantitative approach, in: 2018 IEEE 3rd International Conference on Cloud Computing and Big Data Analysis (ICCCBDA), 2018.
- [P215] I. Graessler, A. Poehler, Intelligent control of an assembly station by integration of a digital twin for employees into the decentralized control system, *Procedia Manufacturing* 24 (2018) 185–189 (2018).
- [P216] M. Krajcovic, P. Grznar, M. Fusko, R. Skokan, Intelligent Logistics for Intelligent Production Systems, *Communications - Scientific letters of the University of Zilina* 20 (2018) 16–23 (2018).
- [P217] E. Kosicka, E. Kozłowski, D. Mazurkiewicz, Intelligent systems of forecasting the failure of machinery park and supporting fulfilment of orders of spare parts, in: *Intelligent Systems in Production Engineering and Maintenance*, 2018.
- [P218] A. Dingli, F. Haddod, Interacting with Intelligent Digital Twins, in: *International Conference on Human-Computer Interaction*, 2019.
- [P219] L. Atorf, J. Roßmann, Interactive Analysis and Visualization of Digital Twins in High-Dimensional State Spaces, in: 2018 15th International Conference on Control, Automation, Robotics and Vision (ICARCV), 2018.
- [P220] M. Priggemeyer, D. Losch, J. Roßmann, Interactive Calibration and Visual Programming of Reconfigurable Robotic Workcells, in: 2018 IEEE/ASME International Conference on Advanced Intelligent Mechatronics (AIM), 2018.
- [P221] C. Steinmetz, A. Rettberg, F. G. C. Ribeiro, G. Schroeder, C. E. Pereira, Internet of Things Ontology for Digital Twin in Cyber Physical Systems, in: VIII Brazilian Symposium on Computing Systems Engineering (SBESC), 2018.
- [P222] M. Bartelt, B. Kuhlenkötter, Involving the Manufacturing System within its Planning Phase, in: 2018 IEEE International Conference on Industrial Engineering and Engineering Management (IEEM), 2018.
- [P223] T. D. West, M. Blackburn, Is Digital Thread/Digital Twin Affordable? A Systemic Assessment of the Cost of DoD's Latest Manhattan Project, *Procedia Computer Science* 114 (2017) 47–56 (2017).
- [P224] H. Zipper, F. Auris, A. Strahilov, M. Paul, Keeping the digital twin up-to-date — Process monitoring to identify changes in a plant, in: IEEE International Conference on Industrial Technology (ICIT), 2018.
- [P225] M. Ringsquandl, S. Lamparter, R. Lepratti, P. Kröger, Knowledge fusion of manufacturing operations data using representation learning, in: *Advances in Production Management Systems. The Path to Intelligent, Collaborative and Sustainable Manufacturing*, 2017.
- [P226] G. Zhou, C. Zhang, Z. Li, K. Ding, C. Wang, Knowledge-driven digital twin manufacturing cell towards intelligent manufacturing, *International journal of Production Research* 58 (2020) 1034–1051 (2020).
- [P227] A. M. Madni, C. C. Madni, S. D. Lucero, Leveraging Digital Twin Technology in Model-Based Systems Engineering, *Systems* 7 (2019).
- [P228] J. David, A. Lobov, M. Lanz, Leveraging Digital Twins for Assisted Learning of Flexible Manufacturing Systems, in: 16th International Conference on Industrial Informatics (INDIN), 2018.
- [P229] S. R. Islavath, D. Deb, H. Kumar, Life cycle analysis and damage prediction of a longwall powered support using 3D numerical modelling techniques, *Arabian journal of Geosciences* 12 (2019) 1–15 (2019).
- [P230] C. E. Kaed, V. Danilchenko, F. Delpech, J. Brodeur, A. Radisson, Linking an Asset and a Domain Specific Ontology for a Simple Asset TimeSeries Application, in: 2018 IEEE International Conference on Big Data (Big Data), 2018.
- [P231] G. Martin, C. Marty, R. Bornoff, A. Poppe, G. Onushkin, M. Rencz, J. Yu, Luminaire Digital Design Flow with Multi-Domain Digital Twins of LEDs, *Energies* 12 (2019).
- [P232] C. Weber, J. Königsberger, L. Kassner, B. Mitschang, M2DDM – A Maturity Model for Data-Driven Manufacturing, *Procedia CIRP* 63 (2017) 173–178 (2017).
- [P233] S. Settemsdal, Machine Learning and Artificial Intelligence as a Complement to Condition Monitoring in a Predictive Maintenance Setting, in: *SPE Oil and Gas India Conference and Exhibition*, 2019.
- [P234] Q. Min, Y. Lu, Z. Liu, C. Su, B. Wang, Machine Learning based Digital Twin Framework for Production Optimization in Petrochemical Industry, *International journal of Information Management* 49 (2019) 502–519 (2019).
- [P235] C. Liu, X. Hong, Z. Zhu, X. Xu, Machine tool digital twin: modelling methodology and applications, in: 48th International Conference on Computers and Industrial Engineering (CIE), 2018.
- [P236] K. Ponomarev, N. Kudryashov, N. Popelnukha, V. Potekhin, Main Principals and Issues of Digital Twin Development for Complex Technological Processes, *Annals of DAAAM & Proceedings* 28 (2017).
- [P237] S. Waschull, J. C. Wortmann, J. A. C. Bokhorst, Manufacturing execution systems: The next level of automated control or of shop-floor support?, in: *Advances in Production Management Systems. Smart Manufacturing for Industry 4.0*, 2018.
- [P238] J. Kim, H. Kim, Y. Ham, Mapping local vulnerabilities into a 3D city model through social sensing and the CAVE system toward digital twin city, in: *Computing in Civil Engineering 2019: Smart Cities, Sustainability, and Resilience*, American Society of Civil Engineers, 2019.
- [P239] C. L. Popa, C. E. Cotet, D. Popescu, M. F. Solea, S. G. Şaşcîm, T. Dobrescu, Material flow design and simulation for a glass panel recycling installation, *Waste Management & Research* 36 (2018) 653–660 (2018).
- [P240] P. Janda, Mechatronic concept of heavy machine tools, in: *International DAAAM Symposium*, 2018.
- [P241] S. Gordon, A. Ryan, S. Loughlin, Meeting The Needs of Industry in Smart Manufacture – The Definition of a New Profession and a Case Study in Providing the Required Skillset, *Procedia Manufacturing* 17 (2018) 262–269 (2018).

- [P242] M. P. Papazoglou, Metaprogramming Environment for Industry 4.0, in: 2018 Sixth International Conference on Enterprise Systems (ES), 2018.
- [P243] P. Aivaliotis, K. Georgoulas, Z. Arkouli, S. Makris, Methodology for enabling Digital Twin using advanced physics-based modelling in predictive maintenance, *Procedia CIRP* 81 (2019) 417–422 (2019).
- [P244] C. Constantinescu, D. Popescu, O. Todorovic, O. Virlan, V. Tinca, Methodology of Realising the Digital Twins of Exoskeleton-Centered Workplaces, *Acta Technica Napocensis-Series: Applied Mathematics, Mechanics, and Engineering* 61 (2018).
- [P245] Naplekov, Ilya, Zheleznikov, Ivan, Pashchenko, Dmitry, Kobysheva, Polina, Moskvitina, Anna, Mustafin, Ravil, Gnutikova, Maria, Mullagalieva, Alina, Uzlov, Pavel, Methods of computational modeling of coronary heart vessels for its digital twin, *MATEC Web of Conferences* 172 (2018).
- [P246] M. Lohtander, E. Garcia, M. Lanz, J. Volotinen, J. Ratava, J. Kaakkunen, Micro Manufacturing Unit – Creating Digital Twin Objects with Common Engineering Software, *Procedia Manufacturing* 17 (2018) 468–475 (2018).
- [P247] M. Lohtander, N. Ahonen, M. Lanz, J. Ratava, J. Kaakkunen, Micro manufacturing unit and the corresponding 3D-model for the digital twin, *Procedia manufacturing* 25 (2018) 55–61 (2018).
- [P248] G. Radchenko, A. Alaasam, A. Tchernykh, Micro-workflows: Kafka and kepler fusion to support digital twins of industrial processes, in: 2018 IEEE/ACM International Conference on Utility and Cloud Computing Companion (UCC Companion), 2018.
- [P249] E. Abisset-Chavanne, J. L. Duval, E. Cueto, F. Chinesta, Model and system learners, optimal process constructors and kinetic theory-based goal-oriented design: a new paradigm in materials and processes informatics, in: *AIP Conference Proceedings*, Vol. 1960, 2018.
- [P250] M. Gonzalez, O. Salgado, J. Croes, B. Plumers, W. Desmet, Model-based state estimation for the diagnosis of multiple faults in non-linear electro-mechanical systems, in: *International Conference on Condition Monitoring of Machinery in Non-Stationary Operation*, 2018.
- [P251] A. S. Ullah, Modeling and simulation of complex manufacturing phenomena using sensor signals from the perspective of Industry 4.0, *Advanced Engineering Informatics* 39 (2019) 1–13 (2019).
- [P252] L. Hu, N.-T. Nguyen, W. Tao, M. C. Leu, X. F. Liu, M. R. Shahriar, S. M. N. Al Sunny, Modeling of Cloud-Based Digital Twins for Smart Manufacturing with MT Connect, *Procedia Manufacturing* 26 (2018) 1193–1203 (2018).
- [P253] Q. Qi, D. Zhao, T. W. Liao, F. Tao, Modeling of Cyber-Physical Systems and Digital Twin Based on Edge Computing, Fog Computing and Cloud Computing Towards Smart Manufacturing, in: *ASME 2018 13th International Manufacturing Science and Engineering Conference*, 2018, p. 7.
- [P254] Q. Zhang, X. Zhang, W. Xu, A. Liu, Z. Zhou, D. T. Pham, Modeling of digital twin workshop based on perception data, in: *Intelligent Robotics and Applications*, 2017.
- [P255] J. Zenisek, J. Wolfartsberger, C. Sievi, M. Affenzeller, Modeling sensor networks for predictive maintenance, in: *On the Move to Meaningful Internet Systems: OTM 2018 Workshops*, 2019.
- [P256] J. Um, J. Popper, M. Ruskowski, Modular augmented reality platform for smart operator in production environment, in: 2018 IEEE Industrial Cyber-Physical Systems (ICPS), 2018.
- [P257] J. Guo, N. Zhao, L. Sun, S. Zhang, Modular based flexible digital twin for factory design, *Journal of Ambient Intelligence and Humanized Computing* 10 (2019) 1189–1200 (2019).
- [P258] M. Vathoopan, M. Johny, A. Zoitl, A. Knoll, Modular Fault Ascription and Corrective Maintenance Using a Digital Twin, *IFAC-PapersOnLine* 51 (2018) 1041–1046 (2018).
- [P259] M. R. Shahriar, S. M. N. A. Sunny, X. Liu, M. C. Leu, L. Hu, N.-T. Nguyen, MTComm Based Virtualization and Integration of Physical Machine Operations with Digital-Twins in Cyber-Physical Manufacturing Cloud, in: 5th IEEE International Conference on Cyber Security and Cloud Computing (CSCloud)/ 4th IEEE International Conference on Edge Computing and Scalable Cloud (EdgeCom), 2018.
- [P260] A. Poppe, G. Farkas, L. Gaál, G. Hantos, J. Hegedüs, M. Rencz, Multi-Domain Modelling of LEDs for Supporting Virtual Prototyping of Luminaires, *Energies* 12 (2019).
- [P261] T. Delbrügger, M. Meißner, A. Wirtz, D. Biermann, J. Myrzik, J. Rossmann, P. Wiederkehr, Multi-level simulation concept for multidisciplinary analysis and optimization of production systems, *The International Journal of Advanced Manufacturing Technology* 103 (2019) 3993–4012 (2019).
- [P262] D. Hauf, S. Süß, A. Strahilov, J. Franke, Multifunctional use of functional mock-up units for application in production engineering, in: 2017 IEEE 15th International Conference on Industrial Informatics (INDIN), 2017.
- [P263] N. Demkovich, E. Yablochnikov, G. Abaev, Multiscale modeling and simulation for industrial cyber-physical systems, in: 2018 IEEE Industrial Cyber-Physical Systems (ICPS), 2018.
- [P264] K. Worden, E. J. Cross, P. Gardner, R. J. Barthorpe, D. J. Wagg, On digital twins, mirrors and virtualisations, in: *Model Validation and Uncertainty Quantification*, volume 3, 2020.
- [P265] D. J. Wagg, P. Gardner, R. J. Barthorpe, K. Worden, On key technologies for realising digital twins for structural dynamics applications, in: *Model Validation and Uncertainty Quantification*, volume 3, 2020.
- [P266] M. Joordens, M. Jamshidi, On The Development of Robot Fish Swarms in Virtual Reality with Digital Twins, in: 13th Annual Conference on System of Systems Engineering (SoSE), 2018.
- [P267] M. Rückert, S. Merkelbach, R. Alt, K. Schmitz, Online life cycle assessment for fluid power manufacturing systems – challenges and opportunities, in: *Advances in Production Management Systems. Smart Manufacturing for Industry 4.0*, 2018.
- [P268] N. Teslya, I. Ryabchikov, Ontology-based semantic models for industrial iot components representation, in: *Proceedings of the Third International Scientific Conference “Intelligent Information Technologies for Industry” (IITI’18)*, 2019.
- [P269] S. V. Nagar, A. C. Chandrashekar, M. Suvarna, Optimized additive manufacturing technology using digital twins and cyber physical systems, in: *Cyber-physical Systems and Digital Twins*, 2020.
- [P270] H. Sun, C. Li, X. Fang, H. Gu, Optimized throughput improvement of assembly flow line with digital twin online analytics, in: *IEEE International Conference on Robotics and Biomimetics (ROBIO)*, 2017.
- [P271] F. Yao, A. Keller, M. Ahmad, B. Ahmad, R. Harrison, A. W. Colombo, Optimizing the Scheduling of Autonomous Guided Vehicle in a Manufacturing Process, in: *IEEE 16th International Conference on Industrial Informatics (INDIN)*, 2018.
- [P272] P. D. Urbina Coronado, R. Lynn, W. Louhichi, M. Parto, E. Wescoat, T. Kurfess, Part data integration in the Shop Floor Digital Twin:

- Mobile and cloud technologies to enable a manufacturing execution system, *Journal of Manufacturing Systems* 48 (2018) 25–33 (2018).
- [P273] A. Karakra, F. Fontanili, E. Lamine, J. Lamothe, A. Taweel, Pervasive computing integrated discrete event simulation for a hospital digital twin, in: *IEEE/ACS 15th International Conference on Computer Systems and Applications (AICCSA)*, 2018.
- [P274] E. Lutters, Pilot production environments driven by digital twins, *South African Journal of Industrial Engineering* 29 (2018) 40–53 (2018).
- [P275] K. Shubenkova, A. Valiev, V. Shepelev, S. Tsiulin, K. H. Reinau, Possibility of Digital Twins Technology for Improving Efficiency of the Branded Service System, in: *Global Smart Industry Conference (GloSIC)*, 2018.
- [P276] A. Mayes, J. Heffernan, L. Jauriqui, R. Livings, E. Biedermann, J. C. Aldrin, B. R. Goodlet, S. Mazdiyasn, Process compensated resonance testing (PCRT) inversion for material characterization and digital twin calibration, in: *AIP Conference Proceedings*, 2019.
- [P277] N. Desai, S. K. Ananya, L. Bajaj, A. Periwal, S. R. Desai, Process parameter monitoring and control using digital twin, in: *Cyber-physical Systems and Digital Twins*, 2020.
- [P278] N. Alaei, A. Rouvinen, A. Mikkola, R. Nikkilä, Product processes based on digital twin, in: *Commercial Vehicle Technology 2018*, Springer, 2018.
- [P279] B. R. Denos, S. G. Kravchenko, R. B. Pipes, B. Pipes, Progressive failure analysis in platelet based composites using CT-measured local microstructure, in: *International SAMPE Technical Conference*, 2017.
- [P280] H. Laaki, Y. Miche, K. Tammi, Prototyping a Digital Twin for Real Time Remote Control Over Mobile Networks: Application of Remote Surgery, *IEEE Access* 7 (2019) 20325–20336 (2019).
- [P281] S. R. Chhetri, S. Faezi, A. Canedo, M. A. A. Faruque, QUILT: Quality Inference from Living Digital Twins in IoT-Enabled Manufacturing Systems, in: *Proceedings of the International Conference on Internet of Things Design and Implementation*, 2019.
- [P282] P. Sharma, D. Knezevic, P. Huynh, G. Malinowski, et al., RB-FEA based digital twin for structural integrity assessment of offshore structures, in: *Offshore Technology Conference*, 2018.
- [P283] V. Gopinath, A. Srija, C. N. Sravanthi, Re-design of smart homes with digital twins, *Journal of Physics: Conference Series* 1228 (2019).
- [P284] K. Samir, A. Maffei, M. A. Onori, Real-Time asset tracking; a starting point for Digital Twin implementation in Manufacturing, *Procedia CIRP* 81 (2019) 719–723 (2019).
- [P285] C. Scheifele, A. Verl, O. Riedel, Real-time co-simulation for the virtual commissioning of production systems, *Procedia CIRP* 79 (2019) 397–402 (2019).
- [P286] E. J. Tuegel, A. R. Ingraffea, T. G. Eason, S. M. Spottswood, Reengineering aircraft structural life prediction using a digital twin, *International Journal of Aerospace Engineering* 2011 (2011).
- [P287] J. Boutrot, Y. Giorgiutti, F. Rezende, S. Barras, Reliable and Accurate Determination of Life Extension for Offshore Units, in: *OTC Offshore Technology Conference*, 2017.
- [P288] S. Balachandrar, R. Chinnaiyan, Reliable digital twin for connected footballer, in: *International conference on computer networks and communication technologies*, 2019.
- [P289] T. Delbrügger, J. Rossmann, Representing adaptation options in experimentable digital twins of production systems, *International Journal of Computer Integrated Manufacturing* 32 (2019) 352–365 (2019).
- [P290] L.-L. Liu, X. Wan, Z. Gao, X. Li, B. Feng, Research on modelling and optimization of hot rolling scheduling, *Journal of Ambient Intelligence and Humanized Computing* 10 (2019) 1201–1216 (2019).
- [P291] Y. Lu, X. Xu, Resource virtualization: a core technology for developing cyber-physical production systems, *Journal of Manufacturing Systems* 47 (2018) 128–140 (2018).
- [P292] I. Verner, D. Cuperman, A. Fang, M. Reitman, T. Romm, G. Balikin, Robot online learning through digital twin experiments: A weightlifting project, in: *Online Engineering & Internet of Things*, 2018.
- [P293] D. Preuveneers, W. Joosen, E. Ilie-Zudor, Robust Digital Twin Compositions for Industry 4.0 Smart Manufacturing Systems, in: *2018 IEEE 22nd International Enterprise Distributed Object Computing Workshop (EDOCW)*, 2018.
- [P294] R. Kloibhofer, E. Kristen, S. Jakšić, Safety and Security in a Smart Production Environment, in: *International Conference on Computer Safety, Reliability, and Security*, 2018.
- [P295] Y. Cai, B. Starly, P. Cohen, Y.-S. Lee, Sensor Data and Information Fusion to Construct Digital-twins Virtual Machine Tools for Cyber-physical Manufacturing, *Procedia Manufacturing* 10 (2017) 1031–1042 (2017).
- [P296] M. Schirrmann, M. Collette, J. Gose, Ship motion and fatigue damage estimation via a digital twin, in: *Life-Cycle Analysis and Assessment in Civil Engineering: Towards an Integrated Vision*, 2018.
- [P297] A. Martins, H. Costelha, C. Neves, Shop Floor Virtualization and Industry 4.0, in: *2019 IEEE International Conference on Autonomous Robot Systems and Competitions (ICARSC)*, 2019.
- [P298] Ø. Kristoffersen, M. Stanko, A. Hoffmann, Short Term Production Optimization Using a Model of the Peregrino Field, Brazil, in: *Offshore Technology Conference Brasil*, 2017.
- [P299] L. Damiani, M. Demartini, P. Giribone, M. Maggiani, R. Revetria, F. Tonelli, Simulation and Digital Twin Based Design of a Production Line: A Case Study, in: *Proceedings of the International MultiConference of Engineers and Computer Scientists*, Vol. 2, 2018.
- [P300] S. Haag, C. Simon, FSimulation Of Horizontal And Vertical Integration In Digital Twins., in: *ECMS*, 2019.
- [P301] T. Cichon, J. Roßmann, Simulation-based user interfaces for digital twins: Pre-, in-, or post-operational analysis and exploration of virtual testbeds, in: *31st Annual European Simulation and Modelling Conference 2017, ESM 2017*, 2017.
- [P302] U. Dahmen, J. Roßmann, Simulation-based verification with experimentable digital twins in virtual testbeds, in: *Tagungsband des 3. Kongresses Montage Handhabung Industrieroboter*, 2018.
- [P303] B. Korth, C. Schwede, M. Zajac, Simulation-ready digital twin for realtime management of logistics systems, in: *2018 IEEE International Conference on Big Data (Big Data)*, 2018.
- [P304] N. Mohammadi, J. E. Taylor, Smart city digital twins, in: *2017 IEEE Symposium Series on Computational Intelligence (SSCI)*, 2017.
- [P305] T. Ruohomäki, E. Airaksinen, P. Huuska, O. Kesäniemi, M. Martikka, J. Suomisto, Smart city platform enabling digital twin, in: *2018 International Conference on Intelligent Systems (IS)*, 2018.
- [P306] H. Lee, T. Kim, Smart factory use case model based on digital twin, *ICIC express letters. Part B, Applications: an international journal of research and surveys* 9 (2018) 931–936 (2018).

- [P307] A. Hehr, M. Norfolk, J. Sheridan, M. Davis, W. Leser, P. Leser, J. A. Newman, Spatial strain sensing using embedded fiber optics, *JOM* 71 (2019) 1528–1534 (2019).
- [P308] A. K. Sahoo, U. Majumder, M. W. Nielsen, J. H. Garm, Strength of Shear Web With Circular Hole in Wind Turbine Blades and Using Digital Twinning Concept to Reduce Material Testing, in: *Gas Turbine India Conference*, 2017.
- [P309] B. R. Seshadri, T. Krishnamurthy, Structural health management of damaged aircraft structures using digital twin concept, in: *25th AIAA/AHS Adaptive Structures Conference*, 2017.
- [P310] D. J. Knezevic, H. Kang, P. Sharma, G. Malinowski, T. T. Nguyen, Structural Integrity Management of Offshore Structures via RB-FEA and Fast Full Load Mapping Based Digital Twins, in: *28th International Ocean and Polar Engineering Conference, Vol. All Days*, 2018.
- [P311] A. Ardanza, A. Moreno, Á. Segura, M. de la Cruz, D. Aguinaga, Sustainable and flexible industrial human machine interfaces to support adaptable applications in the Industry 4.0 paradigm, *International Journal of Production Research* 57 (2019) 4045–4059 (2019).
- [P312] A. Gupta, B. Basu, Sustainable Primary Aluminium Production: Technology Status and Future Opportunities, *Transactions of the Indian Institute of Metals* 72 (2019) 2135–2150 (2019).
- [P313] R. Beregi, Ádám Szaller, B. Kádár, Synergy of multi-modelling for process control, *IFAC-PapersOnLine* 51 (2018) 1023–1028 (2018).
- [P314] W. T. Gruender, Systems engineering requires digital twins of machine elements, in: *CONAT 2016 International Congress of Automotive and Transport Engineering*, 2017.
- [P315] E. Tuegel, The airframe digital twin: some challenges to realization, in: *53rd AIAA/ASME/ASCE/AHS/ASC Structures, Structural Dynamics and Materials Conference 20th AIAA/ASME/AHS Adaptive Structures Conference 14th AIAA*, 2012.
- [P316] S. Konstantinov, M. Ahmad, K. Ananthanarayan, R. Harrison, The cyber-physical e-machine manufacturing system: Virtual engineering for complete lifecycle support, *Procedia CIRP* 63 (2017) 119–124 (2017).
- [P317] P. Sharma, H. Hamedifar, A. Brown, R. Green, et al., The dawn of the new age of the industrial Internet and how it can radically transform the offshore oil and gas industry, in: *Offshore Technology Conference*, 2017.
- [P318] A. J. Zakrajsek, S. Mall, The Development and use of a Digital Twin Model for Tire Touchdown Health Monitoring, in: *58th Structures, Structural Dynamics and Materials Conference*, 2017.
- [P319] N. Nikolakis, K. Alexopoulos, E. Xanthakis, G. Chryssolouris, The digital twin implementation for linking the virtual representation of human-based production tasks to their physical counterpart in the factory-floor, *International Journal of Computer Integrated Manufacturing* 32 (2019) 1–12 (2019).
- [P320] J. Vachálek, L. Bartalský, O. Rovný, D. Šišmišová, M. Morháč, M. Lokšík, The digital twin of an industrial production line within the industry 4.0 concept, in: *2017 21st International Conference on Process Control (PC)*, 2017.
- [P321] E. Glaessgen, D. Stargel, The digital twin paradigm for future NASA and US Air Force vehicles, in: *53rd Structures, Structural Dynamics and Materials Conference*, 2012.
- [P322] J. Van Os, The Digital Twin throughout the Lifecycle, in: *SNAME Maritime Convention*, 2018.
- [P323] T. H.-J. Uhlemann, C. Lehmann, R. Steinhilper, The Digital Twin: Realizing the Cyber-Physical Production System for Industry 4.0, *Procedia CIRP* 61 (2017) 335–340 (2017).
- [P324] J. O. Oyekan, W. Hutabarat, A. Tiwari, R. Grech, M. H. Aung, M. P. Mariani, L. López-Dávalos, T. Ricaud, S. Singh, C. Dupuis, The effectiveness of virtual environments in developing collaborative strategies between industrial robots and humans, *Robotics and Computer-Integrated Manufacturing* 55 (2019) 41–54 (2019).
- [P325] J. Bao, D. Guo, J. Li, J. Zhang, The modelling and operations for the digital twin in the context of manufacturing, *Enterprise Information Systems* 13 (2019) 534–556 (2019).
- [P326] C. Wagner, J. Grothoff, U. Epple, R. Drath, S. Malakuti, S. Grüner, M. Hoffmeister, P. Zimmermann, The role of the Industry 4.0 asset administration shell and the digital twin during the life cycle of a plant, in: *2017 22nd IEEE International Conference on Emerging Technologies and Factory Automation (ETFA)*, 2017.
- [P327] D. A. Zakoldaev, A. V. Gurjanov, A. V. Shukalov, I. O. Zharinov, The projection of cyber and physical systems digital twins in the stage of production technological preparation of the Industry 4.0 smart factories, *IOP Conference Series: Materials Science and Engineering* 537 (2019).
- [P328] Z. Liu, N. Meyendorf, N. Mrad, The role of data fusion in predictive maintenance using digital twin, in: *AIP Conference Proceedings, Vol. 1949*, 2018.
- [P329] U. T. Tygesen, M. S. Jepsen, J. Vestermark, N. Dollerup, A. Pedersen, The true digital twin concept for fatigue re-assessment of marine structures, in: *ASME 37th International Conference on Ocean, Offshore and Arctic Engineering*, 2018.
- [P330] H. Wang, M. Zhou, B. Liu, Tolerance allocation with simulation-based digital twin for CFRP-metal countersunk bolt joint, in: *ASME International Mechanical Engineering Congress and Exposition*, 2018.
- [P331] E. Essa, M. S. Hossain, A. S. Tolba, H. M. Raafat, S. Elmogy, G. Muahmmad, Toward cognitive support for automated defect detection, *Neural Computing and Applications* 32 (2020) 4325–4333 (2020).
- [P332] E. G. Kaigom, J. Roßmann, Toward physics-based virtual reality testbeds for intelligent robot manipulators - an eRobotics approach, in: *IEEE/RSJ International Conference on Intelligent Robots and Systems (IROS)*, 2016.
- [P333] D. N. Mavris, M. G. Balchanos, O. J. Pinon-Fischer, W. J. Sung, Towards a digital thread-enabled framework for the analysis and design of intelligent systems, in: *AIAA Information Systems-AIAA Infotech@ Aerospace*, 2018.
- [P334] D. Ngo, D. A. Guerra-Zubiaga, G. González-Badillo, R. Vatankhah Barenji, Towards a Digital Twin for Cloud Manufacturing: Case Study, in: *ASME International Mechanical Engineering Congress and Exposition*, 2018.
- [P335] D. Heber, M. Groll, et al., Towards a digital twin: How the blockchain can foster E/E-traceability in consideration of model-based systems engineering, in: *Proceedings of the 21st International Conference on Engineering Design (ICED 17)*, 2017.
- [P336] J. Landahl, M. Panarotto, H. Johannesson, O. Isaksson, J. Lööf, et al., Towards adopting digital twins to support design reuse during platform concept development, *Proceedings of NordDesign* (2018).
- [P337] A. M. Miller, R. Alvarez, N. Hartman, Towards an extended model-based definition for the digital twin, *Computer-Aided Design and Applications* 15 (2018).
- [P338] M. Minos-Stensrud, O. H. Haakstad, O. Sakseid, B. Westby, A. Alcocer, Towards Automated 3D reconstruction in SME factories and

- Digital Twin Model generation, in: 2018 18th International Conference on Control, Automation and Systems (ICCAS), 2018.
- [P339] S. Rabah, A. Assila, E. Khouri, F. Maier, F. Ababsa, V. bourny, P. Maier, F. Mérienne, Towards improving the future of manufacturing through digital twin and augmented reality technologies, *Procedia Manufacturing* 17 (2018) 460–467 (2018).
- [P340] M. Eckhart, A. Ekelhart, Towards Security-Aware Virtual Environments for Digital Twins, in: *Proceedings of the 4th ACM Workshop on Cyber-Physical System Security, CPSS '18*, 2018.
- [P341] V. Stojanovic, M. Trapp, R. Richter, B. Hagedorn, J. Döllner, Towards the generation of digital twins for facility management based on 3D point clouds, in: *Proceeding of the 34th Annual ARCOM Conference, Vol. 2018*, 2018.
- [P342] M. Borth, E. van Gerwen, Tracking dynamics in concurrent digital twins, in: *Complex Systems Design & Management*, 2019.
- [P343] I. Verner, D. Cuperman, S. Gamer, A. Polishuk, Training Robot Manipulation Skills through Practice with Digital Twin of Baxter, *International Journal of Online Biomedical Engineering* 15 (2019) 58–70 (2019).
- [P344] F. Longo, L. Nicoletti, A. Padovano, Ubiquitous knowledge empowers the Smart Factory: The impacts of a Service-oriented Digital Twin on enterprises' performance, *Annual Reviews in Control* 47 (2019) 221–236 (2019).
- [P345] S. Settemsdal, et al., Updated case study: The pursuit of an ultra-low manned platform pays dividends in the north sea, in: *Offshore Technology Conference*, 2019.
- [P346] K. E. Thoresen, Å. Kyllingstad, S. Hovland, A. Hetland, Using an Advanced Digital Twin to Improve Downhole Pressure Control, in: *SPE/IADC Drilling Conference and Exhibition*, 2019.
- [P347] A. da Silva Barbosa, F. P. Silva, L. R. dos Santos Crestani, R. B. Otto, Virtual assistant to real time training on industrial environment, in: *Transdisciplinary Engineering Methods for Social Innovation of Industry 4.0: Proceedings of the 25th ISPE Inc. International Conference on Transdisciplinary Engineering*, 2018.
- [P348] T. Lechler, E. Fischer, M. Metzner, A. Mayr, J. Franke, Virtual Commissioning—Scientific review and exploratory use cases in advanced production systems, *Procedia CIRP* 81 (2019) 1125–1130 (2019).
- [P349] J. Xie, X. Wang, Z. Yang, S. Hao, Virtual monitoring method for hydraulic supports based on digital twin theory, *Mining Technology* 128 (2019) 77–87 (2019).
- [P350] S. Burrafato, A. Maliardi, P. Ferrara, T. Grasso, E. De Marchi, R. Campaci, et al., Virtual Reality in D & C: New Approaches Towards Well Digital Twins, in: *Offshore Mediterranean Conference and Exhibition*, 2019.
- [P351] F. Chinesta, E. Cueto, E. Abisset-Chavanne, J. L. Duval, F. El Khaldi, Virtual, digital and hybrid twins: a new paradigm in data-based engineering and engineered data, *Archives of computational methods in engineering* 27 (2020) 105–134 (2020).
- [P352] A. Moreno, G. Velez, A. Ardanza, I. Barandiaran, Á. R. de Infante, R. Chopitea, Virtualisation process of a sheet metal punching machine within the Industry 4.0 vision, *International journal on Interactive Design and Manufacturing (IJIDeM)* 11 (2017) 365–373 (2017).
- [P353] I. Halenar, M. Juhas, B. Juhasova, D. Borkin, Virtualization of Production Using Digital Twin Technology, in: *20th International Carpathian Control Conference (ICCC)*, 2019, pp. 1–5.
- [P354] Z. Zhu, C. Liu, X. Xu, Visualisation of the Digital Twin data in manufacturing by using Augmented Reality, *Procedia CIRP* 81 (2019) 898–903 (2019).
- [P355] G. Baruffaldi, R. Accorsi, R. Manzini, Warehouse management system customization and information availability in 3pl companies, *Industrial Management & Data Systems* 80 (2019).
- [P356] C. Ley, S. P. Bordas, What makes Data Science different? A discussion involving Statistics2.0 and Computational Sciences, *International Journal of Data Science and Analytics* 6 (2018) 167–175 (2018).

Bibliography

- [357] P. Bibow, M. Dalibor, C. Hopmann, B. Mainz, B. Rumpe, D. Schmalzing, M. Schmitz, A. Wortmann, Model-driven development of a digital twin for injection molding, in: S. Dustdar, E. Yu, C. Salinesi, D. Rieu, V. Pant (Eds.), *Advanced Information Systems Engineering*, Springer International Publishing, Cham, 2020, pp. 85–100.
- [358] T. Bolender, G. Bürvenich, M. Dalibor, B. Rumpe, A. Wortmann, Self-adaptive manufacturing with digital twins, in: *2021 International Symposium on Software Engineering for Adaptive and Self-Managing Systems (SEAMS)*, IEEE, 2021, pp. 156–166.
- [359] D. Lehner, J. Pfeiffer, E.-F. Tinsel, M. M. Strljic, S. Sint, M. Vierhauser, A. Wortmann, M. Wimmer, Digital twin platforms: Requirements, capabilities, and future prospects, *IEEE Software* (01) (2021) 0–0 (2021).
- [360] J. C. Kirchhof, B. Rumpe, D. Schmalzing, A. Wortmann, Structurally Evolving Component-Port-Connector Architectures of Centrally Controlled Systems, in: M. Cordy, M. Acher, D. Beuche, G. Saake (Eds.), *International Working Conference on Variability Modelling of Software-Intensive Systems*, ACM, 2020.
- [361] A. Wortmann, O. Barais, B. Combemale, M. Wimmer, Modeling Languages in Industry 4.0: an Extended Systematic Mapping Study, *Software and Systems Modeling* 19 (1) (2020) 67–94 (January 2020).
- [362] K. Hölldobler, B. Rumpe, A. Wortmann, Software Language Engineering in the Large: Towards Composing and Deriving Languages, *Computer Languages, Systems & Structures* 54 (2018) 386–405 (2018).
- [363] S. Singh, E. Shehab, N. Higgins, K. Fowler, T. Tomiyama, C. Fowler, Challenges of Digital Twin in High Value Manufacturing, in: *Aerospace Systems and Technology Conference*, SAE International, 2018.
- [364] D. Olivotti, S. Dreyer, B. Lebek, M. H. Breitner, Creating the Foundation for Digital Twins in the Manufacturing Industry: An Integrated Installed Base Management System, *Information Systems and e-Business Management* 17 (2019) 89–116 (2019).
- [365] M. Ghobakhloo, The Future of Manufacturing Industry: A Strategic Roadmap Toward Industry 4.0, *Journal of Manufacturing Technology Management* 29 (2018) 910–936 (2018).
- [366] L. F. C. S. Durão, S. Haag, R. Anderl, K. Schützer, E. Zancul, Digital Twin Requirements in the Context of Industry 4.0, in: P. Chiabert, A. Bouras, F. Noël, J. Ríos (Eds.), *Product Lifecycle Management to Support Industry 4.0*, 2018.
- [367] K. Y. H. Lim, P. Zheng, C.-H. Chen, A state-of-the-art Survey of Digital Twin: Techniques, Engineering Product Lifecycle Management and Business Innovation Perspectives, *Journal of Intelligent Manufacturing* 31 (2019) 1–25 (2019).

- [368] B. He, K.-J. Bai, Digital Twin-Based Sustainable Intelligent Manufacturing: A Review, *Advances in Manufacturing* 9 (2020) 1–21 (2020).
- [369] E. Negri, L. Fumagalli, M. Macchi, A Review of the Roles of Digital Twin in CPS-based Production Systems, *Procedia Manufacturing* 11 (2017) 939 – 948 (2017).
- [370] M. P. Papazoglou, A. S. Andreou, Smart Connected Digital Factories: Unleashing the Power of Industry 4.0, in: *Cloud Computing and Service Science*, 2019.
- [371] P. Mehta, P. Rao, Z. D. Wu, V. Jovanović, O. Wodo, M. Kuttolamadom, Smart Manufacturing: State-of-the-Art Review in Context of Conventional and Modern Manufacturing Process Modeling, *Monitoring and Control* (2018).
- [372] G. E. Modoni, E. G. Caldarola, M. Sacco, W. Terkaj, Synchronizing Physical and Digital Factory: Benefits and Technical Challenges, *Procedia CIRP* 79 (2019) 472 – 477 (2019).
- [373] F. Tao, H. Zhang, A. Liu, A. Y. C. Nee, Digital Twin in Industry: State-of-the-Art, *IEEE Transactions on Industrial Informatics* 15 (2019) 2405–2415 (2019).
- [374] W. Kritzinger, M. Karner, G. Traar, J. Henjes, W. Sihm, Digital Twin in manufacturing: A categorical literature review and classification, *IFAC* 51 (2018) 1016 – 1022 (2018).
- [375] C. Kan, C. J. Anumba, Digital Twins as the Next Phase of Cyber-Physical Systems in Construction, in: *Computing in Civil Engineering 2019: Data, Sensing, and Analytics*, American Society of Civil Engineers, 2019, pp. 256–264.
- [376] H. van der Valk, H. Haße, F. Möller, M. Arbter, J.-L. Henning, B. Otto, A Taxonomy of Digital Twins, in: *26th Americas Conference on Information Systems (AMCIS)*, 2020, p. 10.
- [377] R. Minerva, G. M. Lee, N. Crespi, Digital Twin in the IoT Context: A Survey on Technical Features, Scenarios, and Architectural Models, *Proceedings of the IEEE* 108 (2020) 1785–1824 (2020).
- [378] J. Autiosalo, J. Vepsäläinen, R. Viitala, K. Tammi, A Feature-Based Framework for Structuring Industrial Digital Twins, *IEEE Access* 8 (2020) 1193–1208 (2020).
- [379] A. Fuller, Z. Fan, C. Day, C. Barlow, Digital Twin: Enabling Technologies, Challenges and Open Research, *IEEE Access* 8 (2020) 108952–108971 (2020).
- [380] L. Barth, M. Ehrat, R. Fuchs, J. Haarmann, Systematization of Digital Twins: Ontology and Conceptual Framework, in: *3rd International Conference on Information Science and System*, 2020.
- [381] M. Héder, From NASA to EU: The Evolution of the TRL scale in Public Sector Innovation, *The Innovation Journal* 22 (2) (2017) 1–23 (2017).
- [382] M. Boeker, W. Vach, E. Motschall, Google Scholar as Replacement for Systematic Literature Searches: Good Relative Recall and Precision are not enough, *BMC Medical Research Methodology* 13 (2013) 1–12 (2013).
- [383] M. Hankel, The Reference Architectural Model Industrie 4.0 (RAMI 4.0), *ZVEI* 2 (2015) 4–9 (2015).
- [384] A. Kleppe, *Software Language Engineering: Creating Domain-Specific Languages using Metamodels*, Addison-Wesley, 2008.
- [385] B. Kitchenham, O. P. Brereton, D. Budgen, M. Turner, J. Bailey, S. Linkman, Systematic Literature Reviews in Software Engineering – A Systematic Literature Review, *Information and Software Technology* 51 (2009) 7–15 (2009).
- [386] K. Petersen, R. Feldt, S. Mujtaba, M. Mattsson, Systematic Mapping Studies in Software Engineering, in: *12th International Conference on Evaluation and Assessment in Software Engineering (EASE)* 12, 2008.
- [387] K. Petersen, S. Vakkalanka, L. Kuzniarz, Guidelines for Conducting Systematic Mapping Studies in Software Engineering: An update, *Information and Software Technology* 64 (2015) 1–18 (2015).
- [388] Regulation (EC) No 1893/2006 of the European Parliament and of the Council of 20 December 2006 establishing the statistical classification of economic activities NACE Revision 2 and amending Council Regulation (EEC) No 3037/90 as well as certain EC Regulations on specific statistical domains (2006).
- [389] International Organization for Standardization, ISO/IEC 15288:2015 systems engineering – system life cycle processes, Tech. rep. (2015).
- [390] I. Kurtev, J. Bézivin, M. Aksit, Technological Spaces: An Initial Appraisal, in: *4th International Symposium on Distributed Objects and Applications*, 2002.
- [391] E. A. Lee, Disciplined heterogeneous modeling, in: *International Conference on Model Driven Engineering Languages and Systems*, 2010.
- [392] B. A. Kitchenham, S. Charters, Guidelines for Performing Systematic Literature Reviews in Software Engineering, Tech. rep., Keele University and Durham University Joint Report (2007).
- [393] D. Budgen, M. Turner, P. Brereton, B. A. Kitchenham, Using Mapping Studies in Software Engineering, in: *PPIG 20th Annual Workshop*, Vol. 8, 2008, pp. 195–204.
- [394] L. M. do Nascimento, D. L. Viana, P. Neto, D. Martins, V. C. Garcia, S. Meira, A Systematic Mapping Study on Domain-Specific Languages, in: *The Seventh International Conference on Software Engineering Advances (ICSEA 2012)*, 2012, pp. 179–187.
- [395] T. Kosar, S. Bohra, M. Mernik, Domain-Specific Languages: A Systematic Mapping Study, *Information and Software Technology* 71 (2016) 77–91 (2016).
- [396] C. Wohlin, P. Runeson, M. Höst, M. C. Ohlsson, B. Regnell, A. Wesslén, *Experimentation in Software Engineering*, Springer, 2012.
- [397] P. Bibow, M. Dalibor, C. Hopmann, B. Mainz, B. Rumpe, D. Schmalzing, M. Schmitz, A. Wortmann, Model-driven development of a digital twin for injection molding, in: *International Conference on Advanced Information Systems Engineering*, 2020, pp. 85–100.
- [398] D. Jones, C. Snider, A. Nassehi, J. Yon, B. Hicks, Characterising the Digital Twin: A Systematic Literature Review, *CIRP Journal of Manufacturing Science and Technology* 29 (2020) 36 – 52 (2020).
- [399] Q. Qi, F. Tao, T. Hu, N. Anwer, A. Liu, Y. Wei, L. Wang, A. Nee, Enabling Technologies and Tools for Digital Twin, *Journal of Manufacturing Systems* 58 (2021) 3–21 (2021).
- [400] R. Stark, T. Damerou, *Digital Twin*, Springer, 2019, pp. 1–8.
- [401] T. R. Wanasinghe, L. Wroblewski, B. K. Petersen, R. G. Gosine, L. A. James, O. De Silva, G. K. I. Mann, P. J. Warrian, Digital Twin for the Oil and Gas Industry: Overview, Research Trends, Opportunities, and Challenges, *IEEE Access* 8 (2020) 104175–104197 (2020).
- [402] J. Ríos, F. Mas, M. Oliva, J. Hernandez-Matias, Framework to support the aircraft digital counterpart concept with an industrial design view, *International Journal of Agile Systems and Management* 9 (2016) 212–231 (2016).
- [403] F. Tao, J. Cheng, Q. Qi, M. Zhang, H. Zhang, F. Sui, Digital Twin-Driven Product Design, Manufacturing and Service with Big Data, The

- International Journal of Advanced Manufacturing Technology 94 (2018) 3563–3576 (2018).
- [404] H. Stachowiak, *Allgemeine Modelltheorie*, Springer, 1973.
 - [405] Y. Lu, K. C. Morris, S. Frechette, Standards Landscape and Directions for Smart Manufacturing Systems, in: *IEEE International Conference on Automation Science and Engineering (CASE)*, 2015, pp. 998–1005.
 - [406] Q. Qi, F. Tao, T. Hu, N. Anwer, A. Liu, Y. Wei, L. Wang, A. Nee, Enabling Technologies and Tools for Digital Twin, *Journal of Manufacturing Systems* 58 (2021) 3–21 (2021).